

**Searchline Excel
Infrared Gas Detectors**

SAFETY

Ensure that you read and understand these instructions **BEFORE** operating the equipment. Please pay particular attention to the Safety Warnings.

WARNINGS

1. The Searchline Excel gas detector is certified for and intended for use in potentially hazardous areas. Install and use the Searchline Excel gas detector in accordance with the latest regulations.
2. For installations in the UK, the Code of Practice SELECTION, INSTALLATION AND MAINTENANCE OF ELECTRICAL APPARATUS FOR USE IN POTENTIALLY EXPLOSIVE ATMOSPHERES should be strictly observed. General recommendations are given in BS EN 60079-14 & IEC 60079-14. Refer to BS EN 60079-29-2 & IEC 60079-29-2 in the UK or the appropriate local or national regulations.
3. For installations in North America, the national Electrical Code (NFPA 70) or later issues should be strictly observed.
4. Elsewhere, the appropriate local or national regulations should be used.
5. The Searchline Excel gas detector must be properly earthed to protect against electrical shock and minimise electrical interference. For electrical installation design considerations refer to Section 3.
6. Operators must be fully aware of the action to be taken if the gas concentration exceeds an alarm level.
7. Dismantling or repair of equipment should be carried out in the safe area only.
8. Test gases may be toxic and/or combustible. Refer to Material Safety Sheets for appropriate warnings.
9. Do not drill holes in any housing as this will invalidate the explosion protection.
10. In order to maintain electrical safety, the unit must not be operated in atmospheres with more than 21% oxygen.
11. Ensure that the bolts which secure flameproof enclosures are fully tightened. The securing bolts used are made from a special certified grade of steel. Only bolts supplied by Honeywell Analytics should be fitted for this purpose.
12. Do not open the enclosure in the presence of an explosive atmosphere.
13. The transmitter unit contains high voltages when operational. These are discharged when the unit is removed from its enclosure.
14. The conduit and cable glands fitted to Searchline Excel should not be modified. If, however, it becomes necessary to make modifications they must comply with the relevant national Codes of Practice.
15. The irradiance and power emitted by the Searchline Excel transmitters is less than 5 mW/mm² and 15 mW/mm² respectively.

SAFETY

CAUTIONS

1. Use only approved parts and accessories with the Searchline Excel gas detector.
2. To maintain safety standards, commissioning and regular maintenance of the Searchline Excel gas detector should only be performed by qualified personnel.

IMPORTANT NOTICES

1. Honeywell Analytics Limited can take no responsibility for installation and/or use of its equipment if this is not done in accordance with the appropriate issue and/or amendment of the manual.
2. The user of this manual should ensure that it is appropriate in all details to the exact equipment to be installed and/or operated. If in doubt, the user should contact Honeywell Analytics Limited for advice.
3. Effect of explosive atmosphere on materials.

Searchline Excel is made from materials which exhibit good resistance to corrosive and solvative substances. The Exd enclosures are made from 316 stainless steel and the explosion protected windows are made from toughened soda lime glass. Honeywell Analytics are not aware of any significant effects of explosive atmospheres upon these materials. Contact Honeywell Analytics or one of their agents for specific queries.

Honeywell Analytics Limited reserve the right to change or revise the information supplied in this document without notice and without obligation to notify any person or organisation of such revision or change.

If further details are required that do not appear in this manual, contact Honeywell Analytics Limited or one of their agents.

Revision History

Revision	Comment	Date
Issue 14	A03864	Nov 2016
Issue 15	A05004	July 2017

CONTENTS

SAFETY	2
1. INTRODUCTION	6
2. OVERVIEW	8
2.1 Introduction	8
2.2 Transmitter	9
2.3 Receiver	10
2.4 Adjustable Mountings	12
3. INSTALLATION AND OPERATION	13
3.1 Introduction	13
3.2 Siting and Mounting	14
3.3 Electrical connections	18
3.4 Power supply	25
3.5 Unpacking	28
3.6 Installation procedure	30
3.7 Alignment and commissioning	36
3.8 System Controller calibration	51
3.9 Installation Checks/Tests	52
4. MAINTENANCE	58
4.1 Inspection and Cleaning	58
4.2 Searchline Excel: Plastic Functional Test Filters – Open Path	58
4.3 Calibration Check using the Gassing Cell	59
4.4 Display Gas Reading	61
4.5 Alignment Telescope	62
4.6 Operational Maintenance (FM)	62
5. PROBLEM SOLVING	63
6. SPECIFICATIONS	68
6.1 System	68
7. CERTIFICATION	70
7.1 General	70
7.2 ATEX & IECEx	71
7.3 UL	77
7.4 CSA/FM	80
7.5 RoHS - Restriction of Hazardous Substances	85

CONTENTS

APPENDIX A - HANDHELD INTERROGATOR	86
A.1 Introduction	86
A.2 Overview	86
A.3 Connection to System	87
A.4 Basic User Tasks	88
A.5 Menus	89
A.6 Problem Solving	103
A.7 specification	104
APPENDIX B - GLOSSARY	106
B.1 Terminology	106
B.2 Measurement Units	106
B.3 Abbreviations	107
APPENDIX C - ACCESSORIES & SPARE PARTS	109
C.1 System Units	109
APPENDIX D - MARINE BRACKET	115
D.1 OVERVIEW	115
D.2 INSTALLATION AND OPERATION	116

1. INTRODUCTION

Searchline Excel is a hydrocarbon gas detection system that is available in two versions:

- **Searchline Excel Open-Path Gas Detector**
- **Searchline Excel Cross-Duct Gas Detector**

For information regarding the Cross-Duct Excel please refer to the Searchline Excel Cross-Duct Technical Handbook, part number 2104M0520.

Searchline Excel Open-Path Gas Detector (OPGD) consists of a Transmitter unit that sends an infrared beam to a Receiver unit up to 200 metres away, and can be located where a flammable hydrocarbon gas cloud is likely to occur.

The detector operates on the principle of infrared (IR) absorption. Gases absorb light at specific wavelengths depending on their molecular composition. Hydrocarbon gases absorb in the infrared region of the spectrum. If a cloud of hydrocarbon gas is present, part of the infrared light is absorbed by the gas, causing a reduction in the signal received that is proportional to the amount of gas in the beam.

The Searchline Excel Transmitter unit produces the infrared light, and the Receiver unit features optical detectors and signal processing electronics. Each unit is housed in a robust stainless steel housing. The Receiver produces a 4 - 20mA analogue output equivalent to 0 - 5 LEL.m (Lower Explosive Limit metres) of gas.

NOTE: THE INFRARED BEAM IS INVISIBLE AND EYE SAFE

Searchline Excel is designed for use in the most demanding environments/applications and provides a sensitive, fast and reliable response. The sophisticated open-path technology provides immunity to sunlight and minimises the effects of environmental factors such as rain, fog, ice, snow and condensation.

The Transmitter and Receiver units incorporate heated optics designed to minimise the build up of humidity, condensation, snow or ice on the glass windows, that could obscure the optics in extreme conditions.

The system is microprocessor controlled with integral self-diagnostics and fault finding facilities.

Local communication between an operator/technician and the gas detector system is made via an associated Handheld Interrogator that uses the Receiver's inbuilt RS485 serial link. The interrogator provides the user with a menu-style interface to select and invoke commands for commissioning and configuring the system, and for viewing the system state and measurements.

The interrogator is connected to the Receiver via one of Honeywell Analytics' DX100 (M) series types of Termination Unit, or via other types of junction box (including the Honeywell OELD smart junction box) using the optional SHC Protection Device. The DX100(M) Termination Units feature an active digital interface that allows a remotely located control centre to monitor the gas detector's signal output and perform basic commands using the Modbus Remote Terminal Unit (RTU) protocol over an RS485 link.

1. INTRODUCTION

This handbook consists of the following parts:

- **Chapter 1** **Introduction**
- **Chapter 2** **System Description**
- **Chapter 3** **Installation And Operation**
- **Chapter 4** **Maintenance**
- **Chapter 5** **Problem Solving**
- **Chapter 6** **Specifications**
- **Chapter 7** **Certification**
- **Appendix A** **Handheld Interrogator**
- **Appendix B** **Glossary**
- **Appendix C** **Accessories & Spare Parts**
- **Appendix D** **Marine Bracket**

Information notices

The types of information notices used throughout this handbook are as follows:



Indicates hazardous or unsafe practice that could result in severe injury or death to personnel.

Caution: Indicates hazardous or unsafe practice which could result in minor injury to personnel, or product or property damage.

Note: Provides useful/helpful/additional information.

If more information beyond the scope of this technical handbook is required please contact Honeywell Analytics.

Associated Documents

Searchline Excel Open-Path Infrared Gas Detector
Basic Installation Guide

Part No: 2104M0510

DX100 Series Termination Units Technical Handbook

Part No: 2104M0701

OELD Operating Instructions

Part No: 3011M5001

2. OVERVIEW

2.1 INTRODUCTION

Each type of Searchline Excel gas detector consists of two units, a Transmitter and a Receiver. This separate Transmitter/Receiver configuration provides the most reliable basis for open path gas detection. For Marine Certified versions and to ensure compliance with this approval, please refer to Appendix D for details of the maritime mounting brackets and associated hardware.

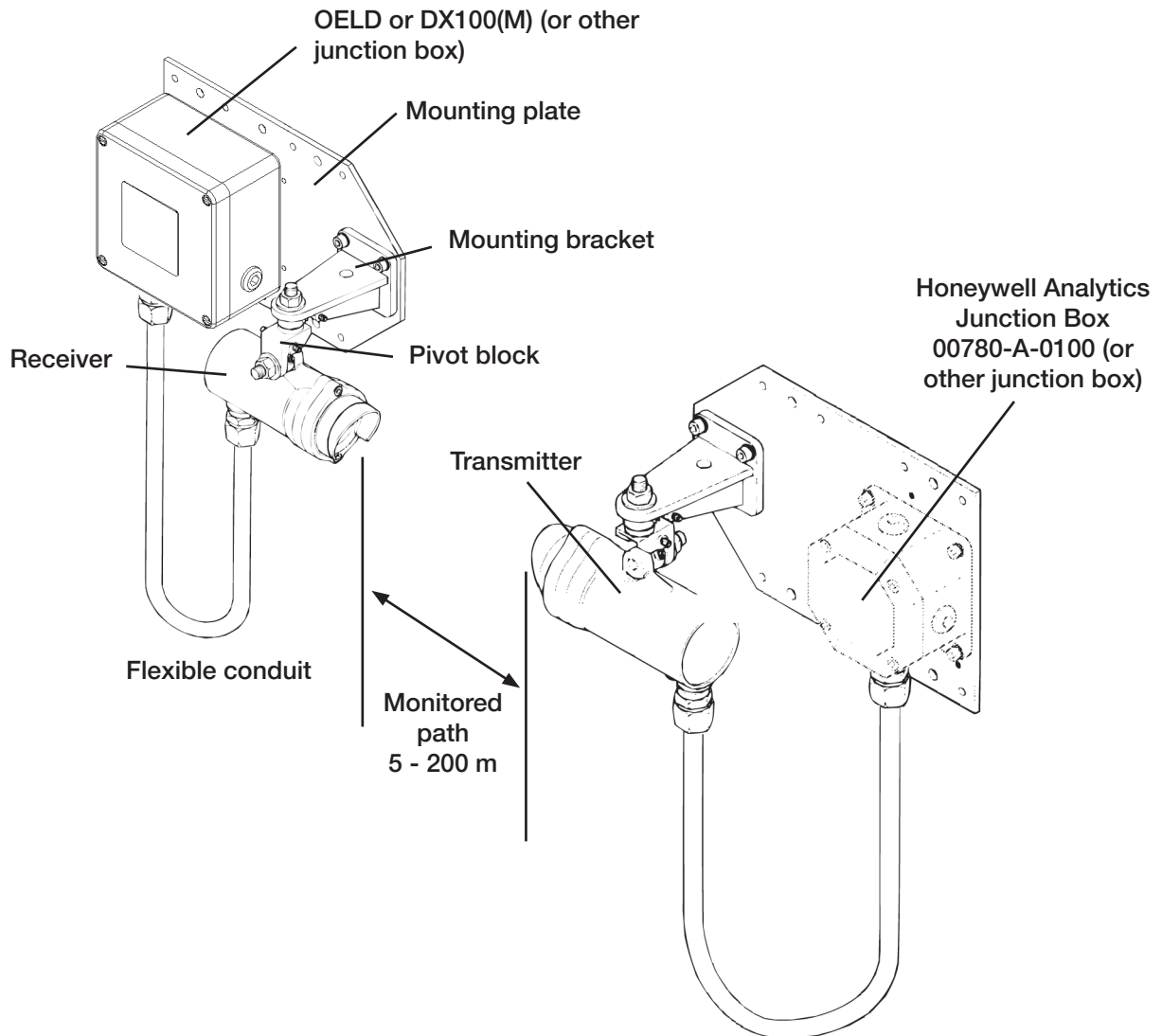

2. OVERVIEW

There are three ranges of Searchline Excel gas detector. These are:

Open-Path	Short Range	5 – 40m	(15ft – 130ft)
	Medium Range	40 – 120m	(130ft – 390ft)
	Long Range	120 – 200m	(390ft – 650ft)

When designing an installation for Searchline Excel it is important that the correct range of the gas detector for each path to be monitored is selected and specified.

The Transmitter and Receiver are each mounted upon robust, adjustable mounting brackets. These brackets bolt to a mounting plate, which is designed to accommodate a variety of junction boxes, accessories and mechanical mounting configurations. The small size and flexibility of Searchline Excel and its mounting arrangements are intended to make correct installation design as simple as possible. Installation details are given in **Chapter 3**.

2.2 TRANSMITTER

The Searchline Excel Transmitter produces an intense, collimated infrared beam which is produced by a Xenon arc flashlamp.

The flashlamp's infrared output is collimated using mirrors which enables a more uniform beam (no chromatic aberrations) to be produced and hence reduces alignment sensitivity. In order to prevent annoying visible flashes, the visible emissions from the flashlamp are blocked by a filter.

The Transmitter's flashlamp is pulsed at precisely 4Hz, each pulse lasting for approximately one microsecond. The precise timing and extremely short duration of these pulses give the Transmitter a very distinctive signature. This distinctive signature makes it easy for the Receiver to distinguish Searchline Excel Transmitter pulses from both natural and artificial sources of infrared radiation.

NOTE: THE INFRARED BEAM IS INVISIBLE AND EYE SAFE.

The medium and long range Transmitters contain a higher power flashlamp and larger optics than the standard short range unit. The resulting infrared beam is many times brighter which allows for a considerable increase in operating range.

2. OVERVIEW

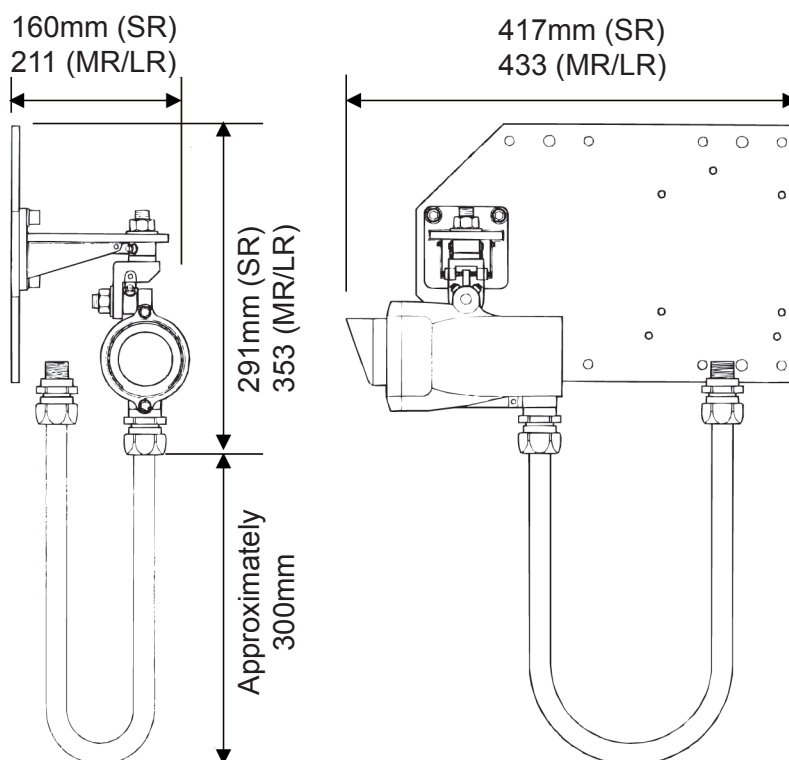

The Transmitter window is heated to minimise condensation, frosting and the build up of snow. During particularly cold operating conditions, the heating of the Transmitter window is increased to turbo levels. The turbo mode can be disabled if not required.

Electrical connections to the Transmitter are made via wires which run through the protective, flexible conduit. There are three Transmitter wires, red (+24V), black (0V) and green/yellow (GND).

2.3 RECEIVER

The Searchline Excel Receiver collects infrared radiation from the Transmitter and performs measurements to enable hydrocarbon gases in the beam path to be detected.

Infrared radiation is collected by a single, silicon lens, which is common to both the sample and reference measurement channels. This radiation is divided by a beamsplitter and fed to two filtered detectors, sample and reference.

The sample detector input is filtered at wavelengths where strong infrared absorption is exhibited by the target gas. The reference detector input is filtered at nearby wavelengths, where strong infrared absorption is **not** exhibited by the target gas. By calculating the ratio of the sample to reference signal it is possible to measure the quantity of gas in the beam, whilst compensating for the effects of rain, fog, dirt etc.

2. OVERVIEW

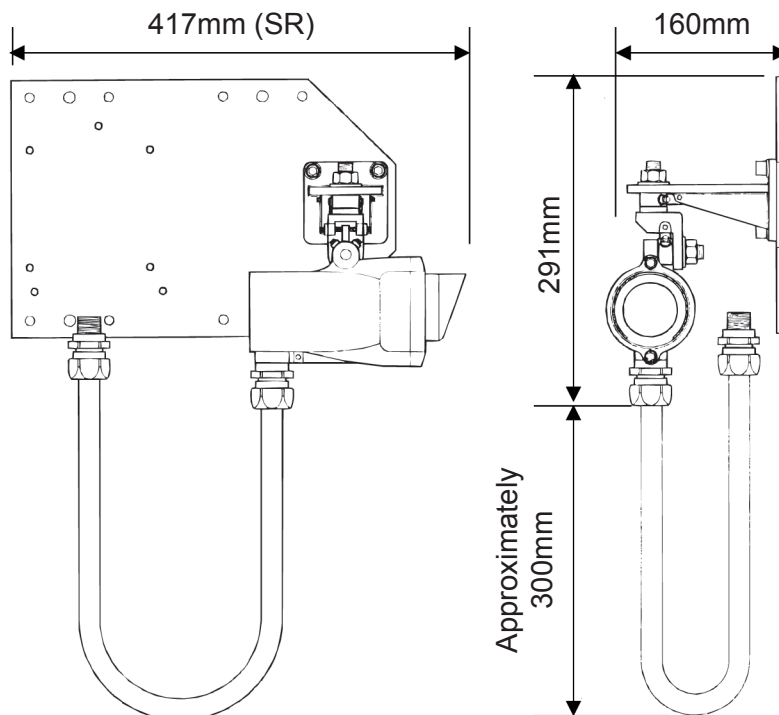

The solid state, photovoltaic detectors used in Searchline Excel provide an exceptional dynamic range and superb temperature and long term stability. These features contribute strongly to the solar immunity and stability of Searchline Excel.

The Receiver contains all of the electronics necessary to amplify, condition and process the signals received by the infrared detectors. The advanced signal processing of Searchline Excel employs two microprocessors.

One microprocessor, the Digital Signal Processor (DSP), is used to perform the necessary intensive signal processing calculations.

The other microprocessor, the microcontroller, controls the overall function of the unit and performs the final calculations to determine the correct gas reading and output state.

The primary output of the Receiver is a signal in the range 4 - 20mA and is available as either source or sink options. For most applications, the output is calibrated for a range of 0 to 5 LEL.m. (See **Appendix B** for the explanation of LEL.m and other terms)

The Receiver also features an RS485 output which is used to communicate with the associated SHC1 Handheld Interrogator. The SHC1 is used to perform final alignment, commissioning, functional testing and diagnostic procedures.

The Receiver window is heated to minimise condensation, frosting and the buildup of snow. The level of heating applied is controlled by the microcontroller and is adjusted from zero to maximum depending on the window temperature.

Electrical connections to the Receiver are made via wires which run through the protective flexible conduit. There are six Receiver wires, red (+24V), black (0V), white (4 - 20mA), orange (RS485 A), blue (RS485 B) and green / yellow (GND).

2. OVERVIEW

2.4 ADJUSTABLE MOUNTINGS

The adjustable mountings are:

- **Purpose-built for Transmitter and Receiver.**
- **Robust.**
- **Rigid and stable.**
- **Made from stainless steel.**
- **Fully adjustable for alignment**

Coarse and fine settings in both horizontal and vertical planes.

Adjustment range:

Vertical $\pm 45^\circ$

Horizontal $\pm 90^\circ$

Alignment details are given in **Chapter 3**.

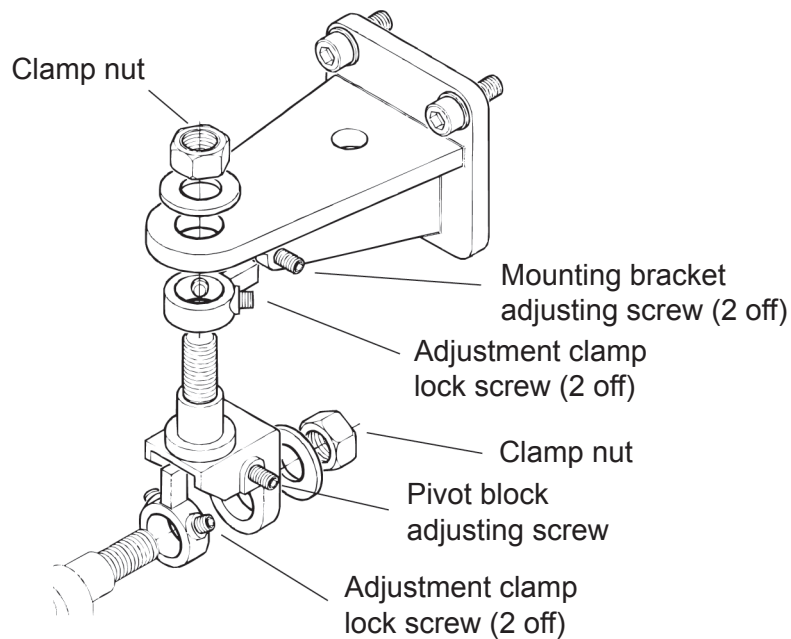

3. INSTALLATION AND OPERATION

3.1 INTRODUCTION

WARNING

The national Code of Practice regarding selection, Installation and maintenance of electrical apparatus for use in potentially explosive atmospheres must be complied with at all times.

Searchline Excel has been designed, engineered and customer tested to be the most robust, reliable Open-Path Gas Detector (OPGD) available to date.

The design and technology employed in Searchline Excel makes it far more resistant to the adverse effects of the operating environment and non-ideal installation engineering than previous generations of OPGDs.

With careful consideration of the intended operating environment and the installation design, the installer/operator can maximise the reliability, availability and performance achieved with Searchline Excel.

Before designing or specifying an installation for Searchline Excel, it is strongly recommended that the installation design authority reads all of this chapter and considers how the information and recommendations provided can be applied to their installation(s).

If you have any queries concerning your installation design, contact Honeywell Analytics or your local agents.

Honeywell Analytics is committed to ensuring that customers achieve reliable operation of their Searchline Excel Gas Detectors. For this reason, Searchline Excel should only be installed by fully trained personnel (trained by Honeywell Analytics or a Honeywell Analytics authorised trainer).

This training will provide the installer with a clear understanding of the Searchline Excel product and the associated accessories and tools. It will also provide familiarity with the installation, alignment and commissioning procedures, plus installation assessment skills to identify potential problem areas.

For each installation, an installation check sheet should be completed and returned to Honeywell Analytics or their agents. Details of this check sheet are given at the end of this chapter.

NOTE: THE INFRARED BEAM IS INVISIBLE AND EYE SAFE.

NOTE: TO ENSURE COMPLIANCE WITH THE MARITIME APPROVAL, REFER TO APPENDIX D FOR COMPONENT IDENTIFICATION AND FOR SPECIAL INSTRUCTIONS ON INSTALLATION, ALIGNMENT AND COMMISSIONING OF THE MARITIME BRACKET.

3. INSTALLATION AND OPERATION

3.2 SITING AND MOUNTING

3.2.1 General

When designing an installation for a Searchline Excel gas detector it is important to give consideration to where it is to be located, what potential sources of problems may be encountered in this location and how the unit is to be mounted and supported.

3.2.2 Location for Best Coverage

Guidance on the positioning of gas detectors to provide the best detection coverage is contained in BS EN 60079-29-2 & IEC 60079-29-2 and other national Codes of Practice. It is recommended that the installation designer consults these Codes of Practice when determining where detectors are to be located. In general, the following positions usually provide the best results:

- **Below potential leak sources for gases that are heavier than air.**
- **Above potential leak sources for gases that are lighter than air.**
- **Near to leak sources, along the expected leak trajectory, taking account of the prevailing wind direction and any other factors which will influence propagation of the leak.**
- **Between possible leak sources and any potential sources of ignition.**

Location to Maximise Reliability and Availability

Care in choosing the location of Excel detectors can contribute significantly to the overall reliability and availability.

When locating units, attempt to avoid areas where they may be adversely affected by the following:

Vibration - Angular vibration of the structure to which Excel units are attached should be kept to less than +/- 0.5°. Where possible, avoid locations where high levels of vibration will be directly induced into the mounting structure. If close proximity to significant sources of vibration is unavoidable, take steps to reduce coupling of this vibration and maximise the rigidity of the mounting structure.

Intense Heat - Excel is certified and specified for operation in environments up to +65°C. If sources of intense heat (flarestacks, intense sunlight, etc.) are present, a sunshade (Part No: 2104B2323) or similar shield should be fitted to the unit to protect it from excessive heating.

Sources of Heavy Contamination - Avoid locations where high levels of contaminants will persistently be blown onto the unit's windows. Potential sources of heavy contamination include generator/turbine exhausts, flarestacks, drilling equipment, process vents/chimneys etc. If sources of heavy contamination cannot be avoided, consider fitting extra shielding and/or providing good access for more routine cleaning.

Snow and Ice in Ambients Below -20°C - The heated optics on Excel units will melt snow or

3. INSTALLATION AND OPERATION

ice on the windows in ambient temperatures down to approximately -20°C.

Below this temperature, snow or ice blown onto the window will not be melted until the ambient temperature rises. If long-term, outdoor operation in very cold climates is intended, it is recommended that extra shielding/covers are employed to prevent snow/ice from being blown onto the windows and building up.

Note: The heated optics have not been evaluated as part of the performance testing relating to the FM approval and therefore are not considered part of the performance approval.

Deluge and Flooding - Searchline Excel is rated IP66/67 and as such will not be damaged by occasional deluge or flooding. However, during such instances the unit will completely lose its IR signal and will enter the BEAM-BLOCK/FAULT state. Also, when the deluge/flooding subsides, there is the possibility that contaminants will be left on the windows. Therefore, it is recommended that Excel units be located away from areas particularly prone to deluge or flooding.

Areas Prone to Subsidence and Settling - Where possible, it is recommended that Excel units are not mounted on structures located where problems with subsidence, settling or thawing of permafrost are known to cause significant movement. If such locations cannot be avoided, the foundations of the mounting structure should be engineered to minimise any angular movements.

Areas Prone to Earthquakes - In locations prone to earthquakes, there is a chance that during or after an earthquake, the units of an Excel gas detector will become misaligned with respect to each other. Provided that the Excel units do not suffer from direct mechanical impact damage during an earthquake, they should remain undamaged by such events. Anti-vibration mounts are unlikely to be of any benefit and are not recommended. After an earthquake it is recommended that Excel gas detectors are visited and their alignment be checked.

Accidental Impact - Locations where there is a significant likelihood of equipment, personnel or moving objects accidentally knocking Excel units out of alignment should where possible be avoided. If such locations cannot be avoided, measures including improved mechanical protection and warning notices should be considered.

Intense Electromagnetic Fields - Searchline Excel complies with EN61000-6-3 and EN61000-6-2 (to industrial levels) in addition to the stringent requirements laid out in DNVGL-CG-0339. As such, the system is well protected from interference by electromagnetic fields. However, locations in close proximity to radio/radar transmitters, heavy electrical plant and high voltage power cables may experience field strengths in excess of those specified in EN61000-6-3 and EN61000-6-2. Where possible, such locations should be avoided or units should be installed as far as possible from the source of the electromagnetic field. Measures including additional screening, filtering and transient suppression may also be of benefit in such locations.

3.2.3 Beam Path

The Transmitter and Receiver units windows should face each other across the area to be protected and, depending on the range of the Transmitter in use, should be the following distance apart:

3. INSTALLATION AND OPERATION

Excel Gas Detector type	Path length between units	
Short Range	5 - 40m	(15 - 130ft)
Medium Range	40 - 120m	(130 - 390ft)
Long Range	120 - 200m	(390 - 650ft)

The beam path and immediate surrounds should be kept free of obstructions that might hinder the free movement of air in the protected area or block the infrared beam. A clear beam path of 20cm diameter or greater is recommended. In particular, for optimum availability, avoid areas affected by the following.

- a. Steam vents and plumes
- b. Smoke stacks and chimneys
- c. Walkways and personnel areas
- d. Splash and spray, e.g. from moving equipment, cooling towers, etc.
- e. Parking, loading, cranes, vehicle temporary stops, e.g. bus stops, road junctions, etc.
- f. Vegetation, e.g. shrubs, bushes, branches, etc. - if currently clear, movement due to weather and future growth or planting must be considered

Note: Where c. and e. cannot be avoided, consider indicating the beam by marking the walkway or road with paint.

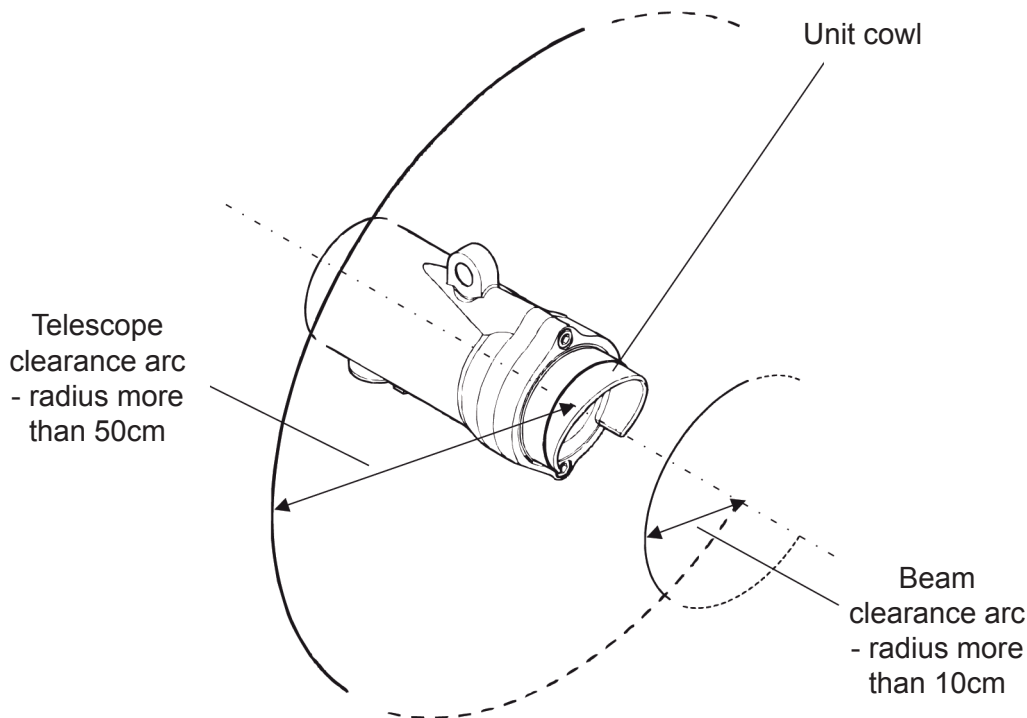

Notes:

1. *In order to fit the alignment telescope, used during the alignment process, a clear accessible arc of at least 50cm radius is required close to the unit's cowling as shown.*
2. *A clear beam path of at least 10cm radius or greater is recommended.*

3. INSTALLATION AND OPERATION

3.2.4 Supporting Structure

The Transmitter and Receiver units should be fixed to a **stable** supporting structure using the mounting plates supplied.

Note: The maximum movement of the supporting structure under all anticipated operating conditions must be $\pm 0.5^\circ$.

If either unit is to be free standing and not mounted to existing supports or structures, and the height above the ground is no more than 3m, the supporting structure shown is recommended:

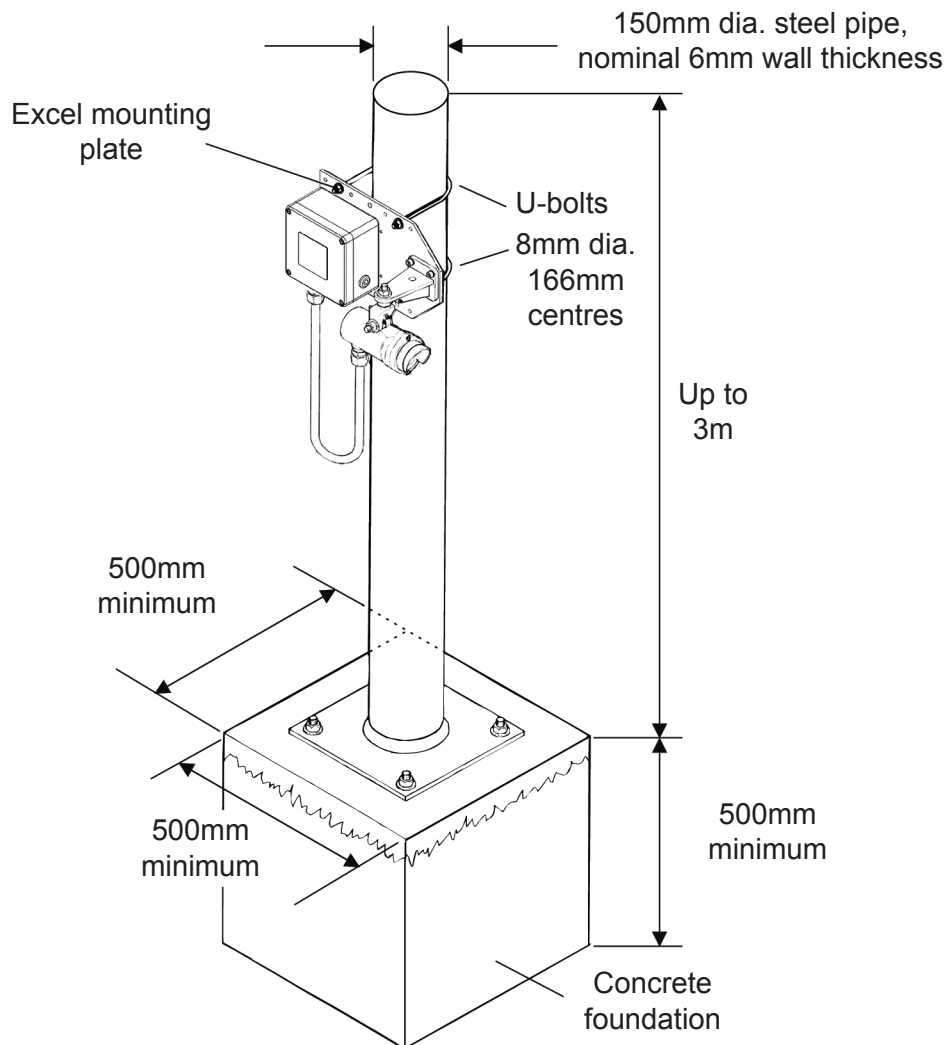

Note: The pipe can be filled with concrete to provide extra robustness if necessary.

3.2.5 Orientation

Searchline Excel is solar immune and therefore there is no need to take account of the sun's movement when considering orientation.

When positioning the units do not install them with the optical axis at an angle greater than 45° to the horizontal. This is to avoid dirt/water buildup on the windows.

3. INSTALLATION AND OPERATION

3.3 ELECTRICAL CONNECTIONS

3.3.1 General

All ranges of Searchline Excel comply with the EMC requirements EN50270. In order to maintain compliance with these standards it is essential that the electrical installation of Excel is engineered correctly.

Electrical installation standards vary for different countries, companies and applications and it is the responsibility of the installation design authority to determine the applicable standards and ensure compliance with them. When designing electrical installations for Excel, Honeywell Analytics recommend that the installation design authority considers the following:

Any earthing regime employed must avoid earth loops.

The following information is provided to assist with proper earthing of Searchline Excel:

- Searchline Excel has an earth wire (green and yellow) for connection to protective earth. This is connected to the enclosure and isolated from the other wires. Maximum voltage between earth and the other wires is 350 V.
- There is an earthing point on the outside of the Searchline Excel enclosure for connection to protective earth.
- Searchline Excel does not require an “instrument earth” connection.

In addition, consider the following points:

General recommendations

1. In general, correctly engineered star earthing arrangements minimise earth current crosstalk and noise, improving the reliability and performance of instrumentation.
2. The use of a single, screened / shielded cable for each field device ensures good screening / shielding and reduces crosstalk.

Field Cabling

1. The entire length of the field cabling connected to a unit should be screened / shielded. The screen / shield should be connected to a low noise instrument earth at one end.
2. The screens / shields of field cabling must not be connected in a manner that creates earth loops or that will result in the screens / shields carrying large currents from heavy plant or equipment.
3. If armoured cable is being used it is necessary to prevent the armour becoming connected to the screen / shield.
4. For installations where the field cable conductors run through conduit or armour connected to protective earth, the conduit or armour should not be considered as a sufficient screen / shield. A separate cable screen / shield, connected to a low noise instrument earth should be employed.
5. The field cabling conductors should have sufficient cross sectional area to ensure that the minimum supply voltage at the field device is 18 Vdc.

3. INSTALLATION AND OPERATION

Maximum voltages

1. Any earthing arrangement employed should ensure that the maximum peak voltage between the unit's case earth and any field cable conductor is less than 350 V. This includes conditions where transient surge voltages are generated by lightning or the switching of heavy electrical plant. Earthing arrangements that employ multiple protective earths or earth grids significantly increase the likelihood of large transient surge voltages being generated between a unit's case earth and the field cable conductors. If it is suspected that voltages between the unit's case earth and any field cable conductor may exceed 350 V it is strongly recommended that surge suppression devices be installed close to the unit.

Note: Suitable, certified surge suppression devices include MTL's TP-48-I-NDI and Pepperl & Fuchs' FN-LB-1. Surge suppression devices should be checked regularly and replaced if necessary.

Interference and noise

1. For installations in Europe, all electrical equipment connected to the system should comply with EN50270. For non-European installations, electrical equipment connected to the system should comply with applicable national or international EMC standards.
2. Any electrical interference induced onto the conductors of a 4 – 20 mA loop by the installation must be kept below the levels necessary to comply with the requirements of EN60079-29-1 or other applicable gas detector performance requirements / standards. In practice, this means that peak noise currents induced on the current loop should be no greater than ± 0.25 mA.
3. The 0 V rail of the control card/control system is often directly connected to one side of the 4-20 mA current sensing resistor. Electrical noise on this rail is therefore directly connected to the 4-20 mA input. In order to avoid additional noise being induced on the 0 V rail, it should not be commoned with the protective earth, which frequently carries a high level of electrical noise.
4. Ideally, the 24 V supply reaching units should be free from large transients, fluctuations or high frequency noise.
5. In order to reduce the likelihood of radio frequency interference affecting the operation of units it is recommended that neither units nor their cabling are installed in close proximity to the antennae of high powered radio, radar or satellite communication equipment.

3. INSTALLATION AND OPERATION

3.3.2 Receiver Connections via OELD

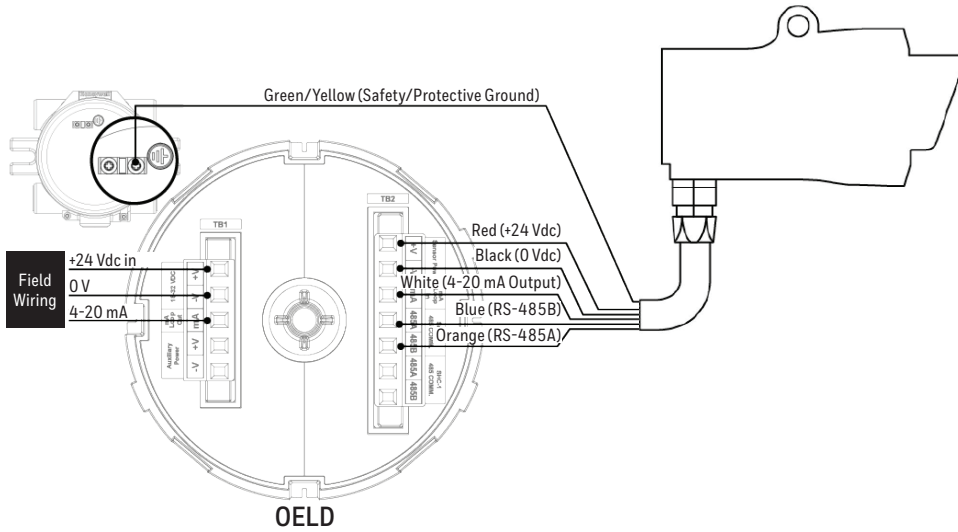

3. INSTALLATION AND OPERATION

3.3.3 Receiver Connections via DX100(M)

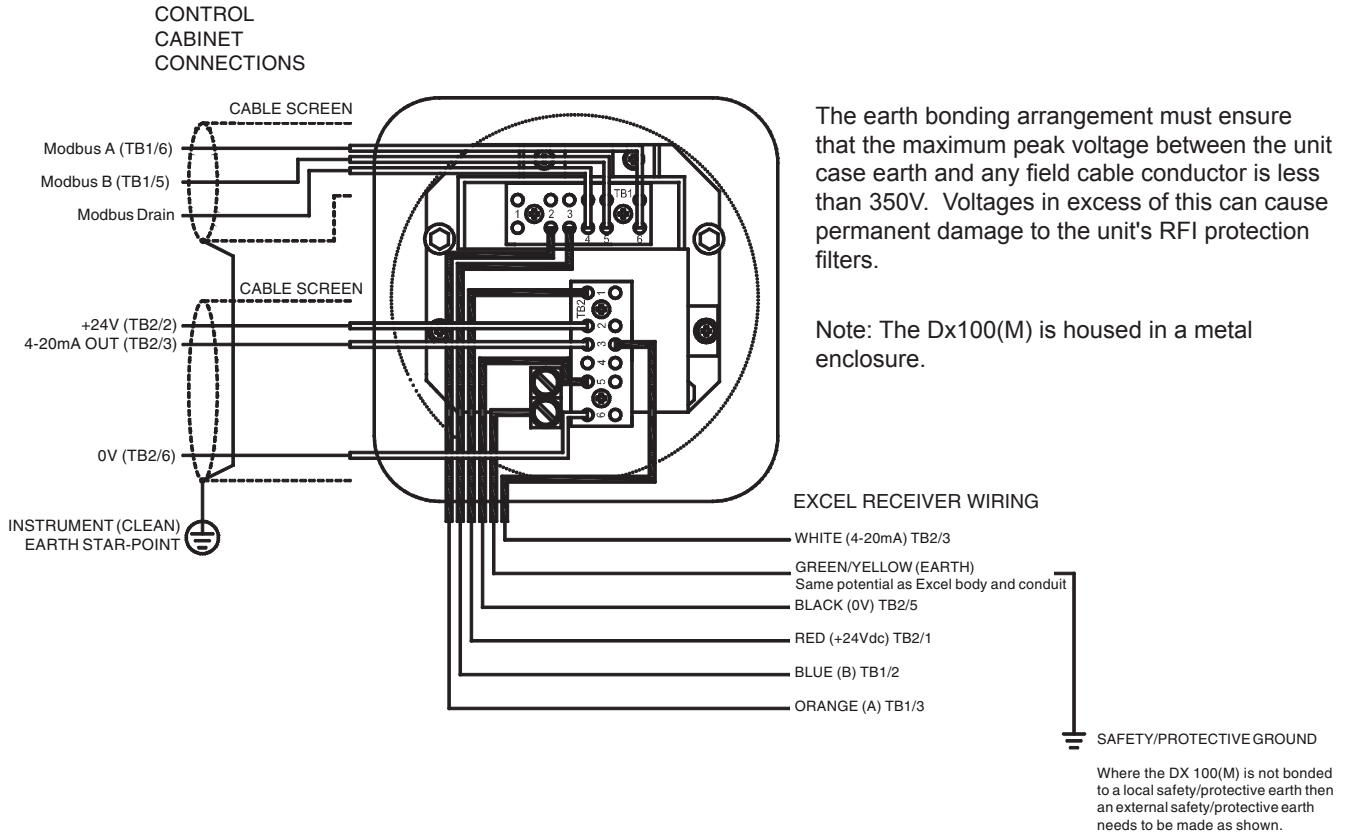

3. INSTALLATION AND OPERATION

3.3.4 Transmitter Connections

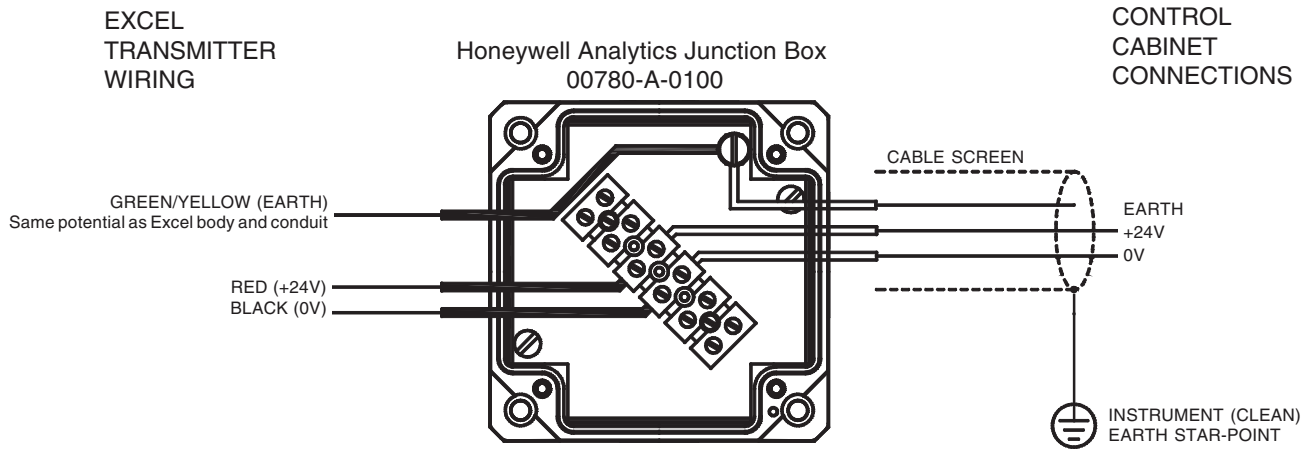

The earth bonding arrangement must ensure that the maximum peak voltage between the unit case earth and any field cable conductor is less than 350V. Voltages in excess of this can cause permanent damage to the unit's RFI protection filters.

Note: Using metal cable glands may connect the armour of the cable to the Excel Body.

3. INSTALLATION AND OPERATION

3.3.6 Remote Installations

For remote or difficult-to-access installations, the OELD or DX100(M) can be positioned in a convenient location by using an intervening junction box (e.g. Hawke/Bartec) attached to the receiver's mounting plate. Alternatively an SHC Calibrator Connector System (part number 2104B6250) can be used that enables connection of the SHC1 up to 10 meters from the receiver.

A maximum cable length of 1km between the unit and the DX100(M) is permissible (RS485 compliant).

The connections are as follows:

Wiring with OELD

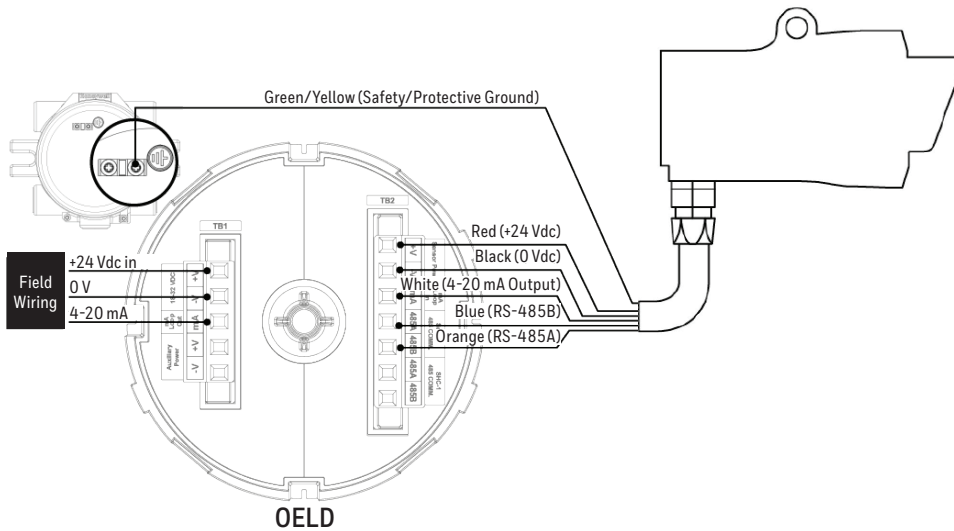

3. INSTALLATION AND OPERATION

Wiring with DX100(M)

See also DX100 Termination Unit's technical Handbook.

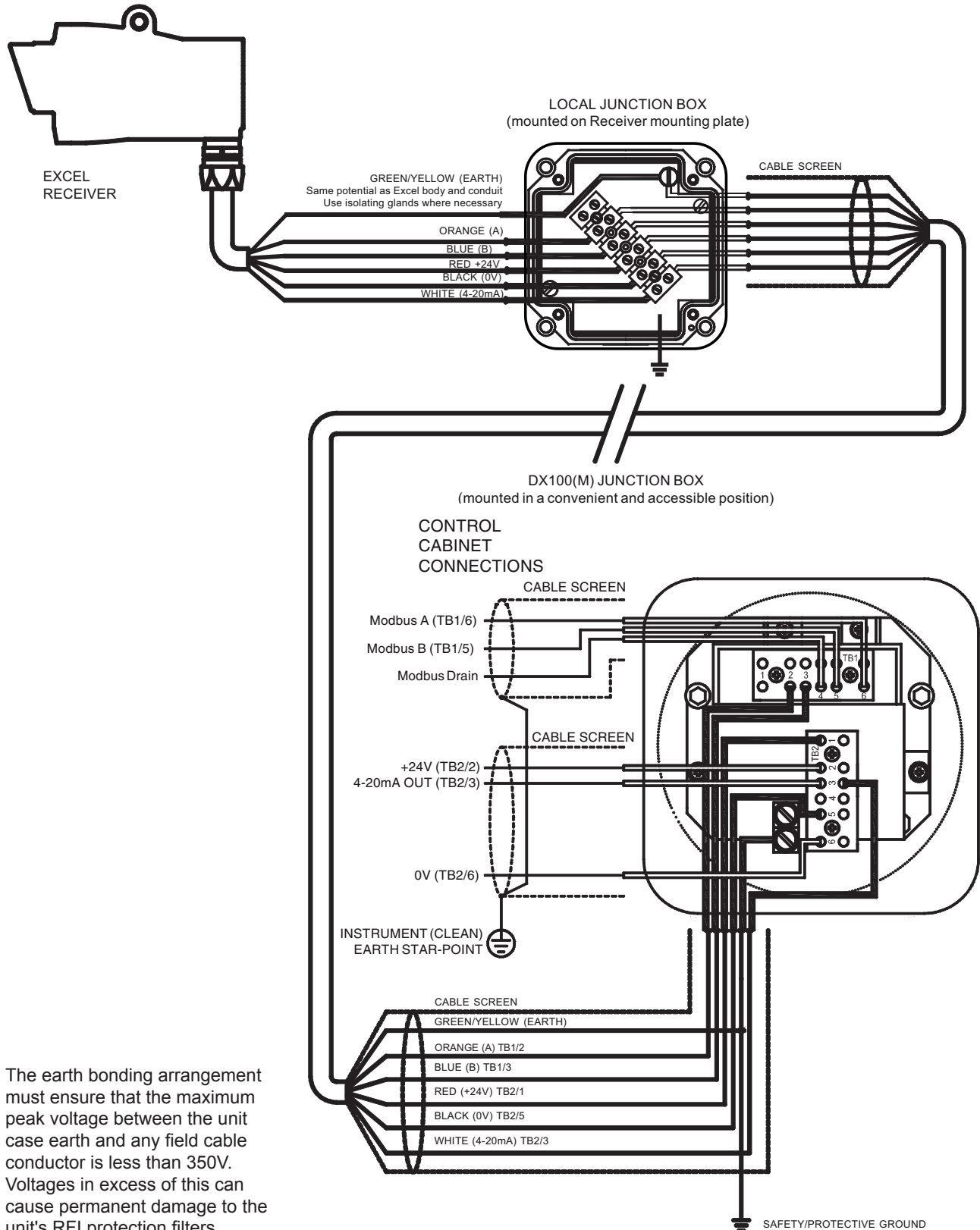

The earth bonding arrangement must ensure that the maximum peak voltage between the unit case earth and any field cable conductor is less than 350V. Voltages in excess of this can cause permanent damage to the unit's RFI protection filters.

3. INSTALLATION AND OPERATION

3.4 POWER SUPPLY

3.4.1 General

The Searchline Excel gas detector requires a power supply from the controller of between 18 VDC and 32 VDC. Ensure that a minimum supply of 18 VDC is measured at the detector, taking into account the voltage drop due to cable resistance.

The maximum loop resistance in the field cable is calculated as follows ($R = V/I$)

$$R \text{ loop} = (V \text{ controller} - V \text{ detector min}) / I \text{ detector}$$

Example 1

The controller is supplying a nominal 24 VDC (**V controller**), the detector minimum allowable voltage is 18 VDC (**V detector min**), therefore the maximum allowable voltage drop between the controller and detector is **6 V**, which means a voltage drop of **3 V** in each core (+ve core and -ve core).

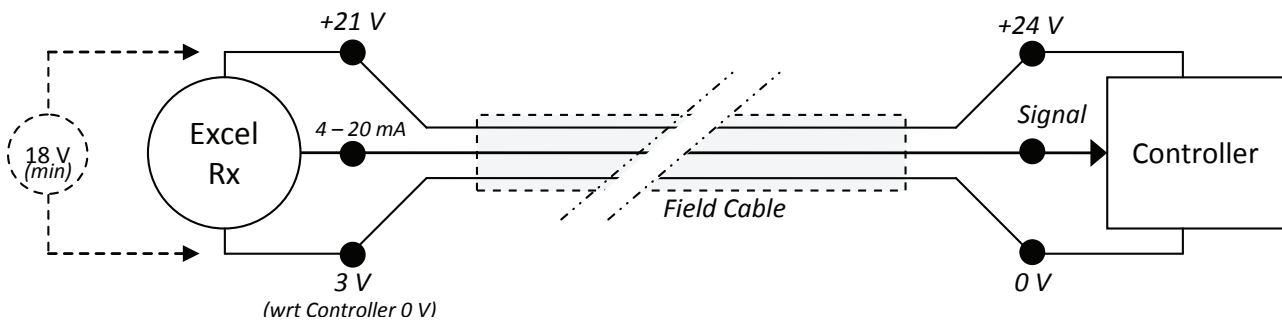

Example 2

Assume that the power consumption of an Excel receiver (Rx) is 8.0 W. The current required to drive the receiver at the minimum voltage ($P / V = I$) is $8.0 / 18 = 444 \text{ mA}$ ($I \text{ detector}$).

So, the maximum field cable loop resistance ($R \text{ loop}$) would be $6 / 0.44 = 13.5$, and $13.5 / 2 = 6.75 \Omega$ per core, (allowing for component variations, losses, etc.).

3. INSTALLATION AND OPERATION

3.4.2 Power Consumption of Excel Components (Typical)

Component	Watts	W / V = I	Allowable Loop Resistance (6 V drop / I) Ω
Receiver	8.0	444 mA	13.50 Ω
Transmitter Short Range Non-Turbo mode	3.5	194 mA	30.93 Ω
Transmitter Short Range Turbo mode	5.0	278 mA	21.58 Ω
Transmitter Mid Range Non-Turbo mode	10.0	555 mA	10.81 Ω
Transmitter Mid Range Turbo mode	12.0	666 mA	9.00 Ω
Transmitter Long Range Non-Turbo mode	10.0	555 mA	10.81 Ω
Transmitter Long Range Turbo mode	12.0	666 mA	9.00 Ω

Example

The following table shows the maximum cable distances for different cable sizes between the controller and a typical device assuming a voltage drop of 3 V in each cable core.

Remember that a cable loop is two cores, so the calculated distance for one core is the loop resistance halved. I.e. $13.5 \Omega / 2 = 6.75 \Omega$ per core.

Receiver calculation = $1000 \times 6.75 \Omega / (\Omega / \text{km})$				
Typical cable resistance			Maximum cable length*	
Cable	Ω / km	Ω / mi	Meters	Feet
0.5 mm ² (20 AWG)	36.8	59.2	183	600
1.0 mm ² (17 AWG)	19.5	31.4	346	1135
1.5 mm ² (16 AWG)	12.7	20.4	531	1742
2.0 mm ² (14 AWG)	10.1	16.3	668	2191
2.5 mm ² (13 AWG)	8.0	12.9	844	2769
AWG is nearest equivalent			*example is for a nominal 24 VDC supply	

Note: The figures given in the table above are typical ratings that may vary from cable to cable. Always measure your own cable and device resistances and your power supplies to ensure accuracy in your calculations.

3. INSTALLATION AND OPERATION

3.4.3 Power Supply Connections - Turbo heating Disabled

When connected as shown in section **3.3.4 Transmitter Connections** all ranges of Transmitter have turbo heating mode enabled.

This means that during conditions of low ambient temperature, additional heating power is applied to the unit's window to minimise condensation, frosting and snow buildup.

If the application/installation does not require turbo heating, reduced power consumption or longer cable loops can be achieved by disabling this mode.

The turbo heating is disabled by reversing the power supply connections to the Transmitter as shown in the following diagram. All other connections remain the same.

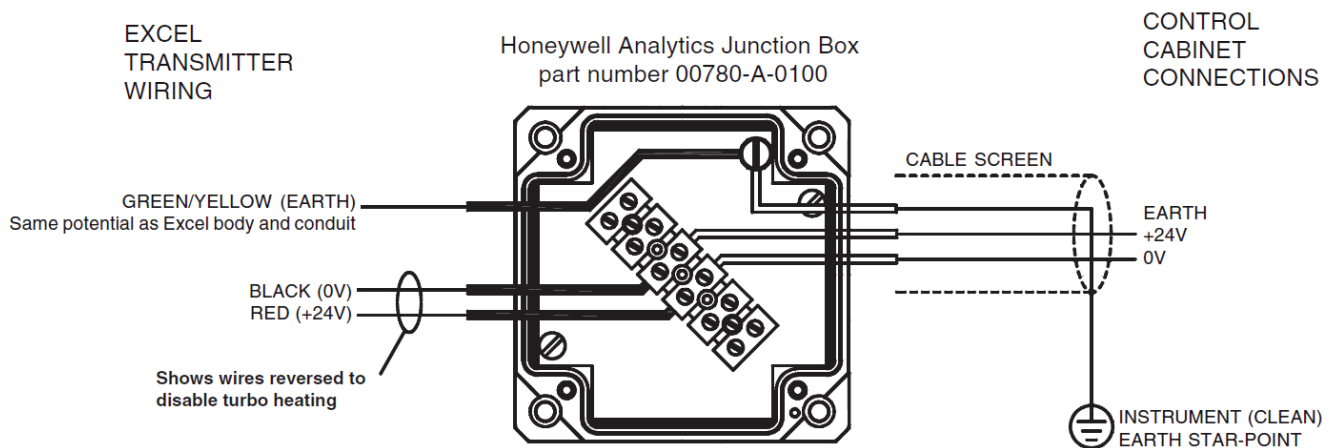

The earth bonding arrangement must ensure that the maximum peak voltage between the unit case earth and any field cable conductor is less than 350V. Voltages in excess of this can cause permanent damage to the unit's RFI protection filters.

Notes:

1. Only Transmitters have turbo mode heating which can be disabled. The Receiver uses proportional heating, which cannot be disabled.
2. Even with turbo mode heating disabled the Transmitter window still receives standard levels of heating.
3. Do not reverse the Receiver power supply connections. This will not damage the unit, but the unit will not function.

3. INSTALLATION AND OPERATION

3.5 UNPACKING

- (1) Carefully unpack the equipment, observing any instructions that may be printed on or contained within the packaging.
- (2) Check the contents for damage and against the packing note for deficiencies.

In the event of damage or loss in transit, notify the carrier and Honeywell Analytics or your local agent immediately.

The gas detector consists of the following items:

Where alternative component sizes are given the size depends on the version of unit, i.e. mid/long range version or short range version.

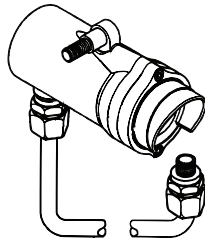

1 x Receiver Unit

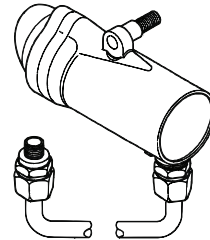

1 x Transmitter Unit

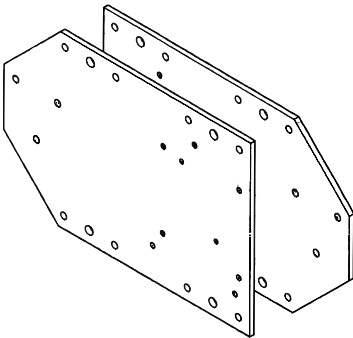

2 x Mounting Plates

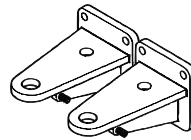

**2 x Mounting Brackets
(with grub screws)**

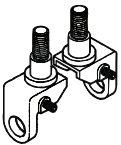

**2 x Pivot Blocks
(with grub screws)**



**4 x Adjustment Clamps
(with grub screws)**

NOTE: REFER TO APPENDIX 4 FOR COMPONENT IDENTIFICATION AND FOR SPECIAL INSTRUCTIONS ON INSTALLATION, ALIGNMENT AND COMMISSIONING OF THE MARITIME BRACKET.

3. INSTALLATION AND OPERATION



4 x Nuts



6 x Mounting Bracket
Fixing Bolts , Internal Lock
Washers and Plain Washers
(M10 or M12)



8 x Junction box Mounting Bolts

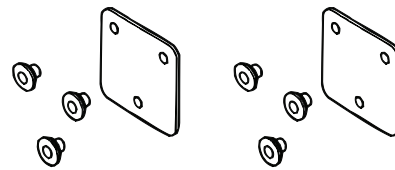

2 x Isolation Kits



4 x Spring Washers (M12 or M16)

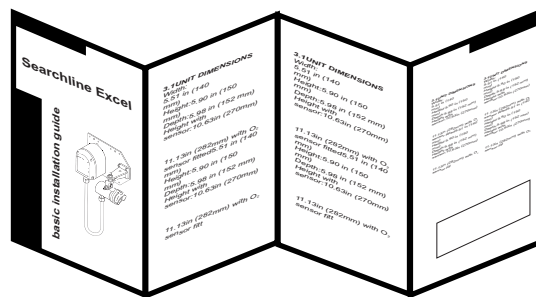

Basic Installation Guide

2 x Allen (Hex) Keys (3mm)

- (3) Ensure that the installer/end user of the equipment receives the technical documentation (operating instructions, manuals, etc.) contained in the packaging.

3. INSTALLATION AND OPERATION

3.6 INSTALLATION PROCEDURE

3.6.1 General

Searchline Excel is designed to allow installation and alignment to be performed by a single technician.

The installation procedure is split into mechanical installation and electrical installation. Each unit needs to be mounted to a supporting structure before making the electrical connections.

3.6.2 Mechanical Installation

The mechanical installation procedure applies to both the Receiver and the Transmitter.

- (1) Ensure that the gas detector equipment supplied is compatible with the required application (i.e. short, medium or long range).
- (2) Fit the mounting bracket and isolation kit to the mounting plate for the unit as shown:

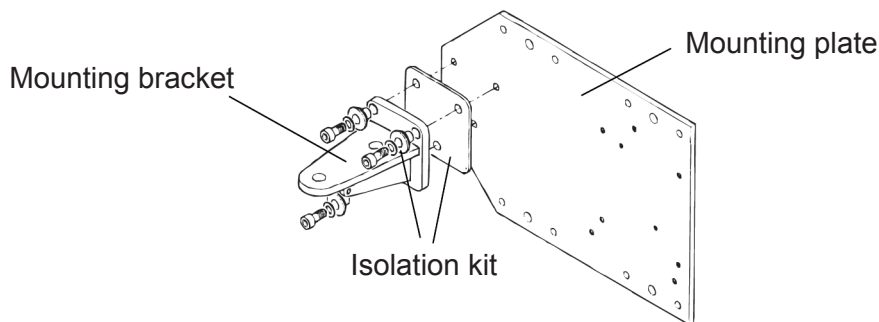

- (3) Fit the mounting plate to the supporting structure.
The plate can be fitted in one of the following ways:
 - a. *With bolts directly to a flat surface.*
 - b. *With U-bolts (2 off) to a single 150mm diameter pipe or pole.*
 - c. *With U-bolts (4 off) to two 55mm diameter pipes or poles, 166mm apart.*

Identify the required mounting holes from the following drawing and table:

3. INSTALLATION AND OPERATION

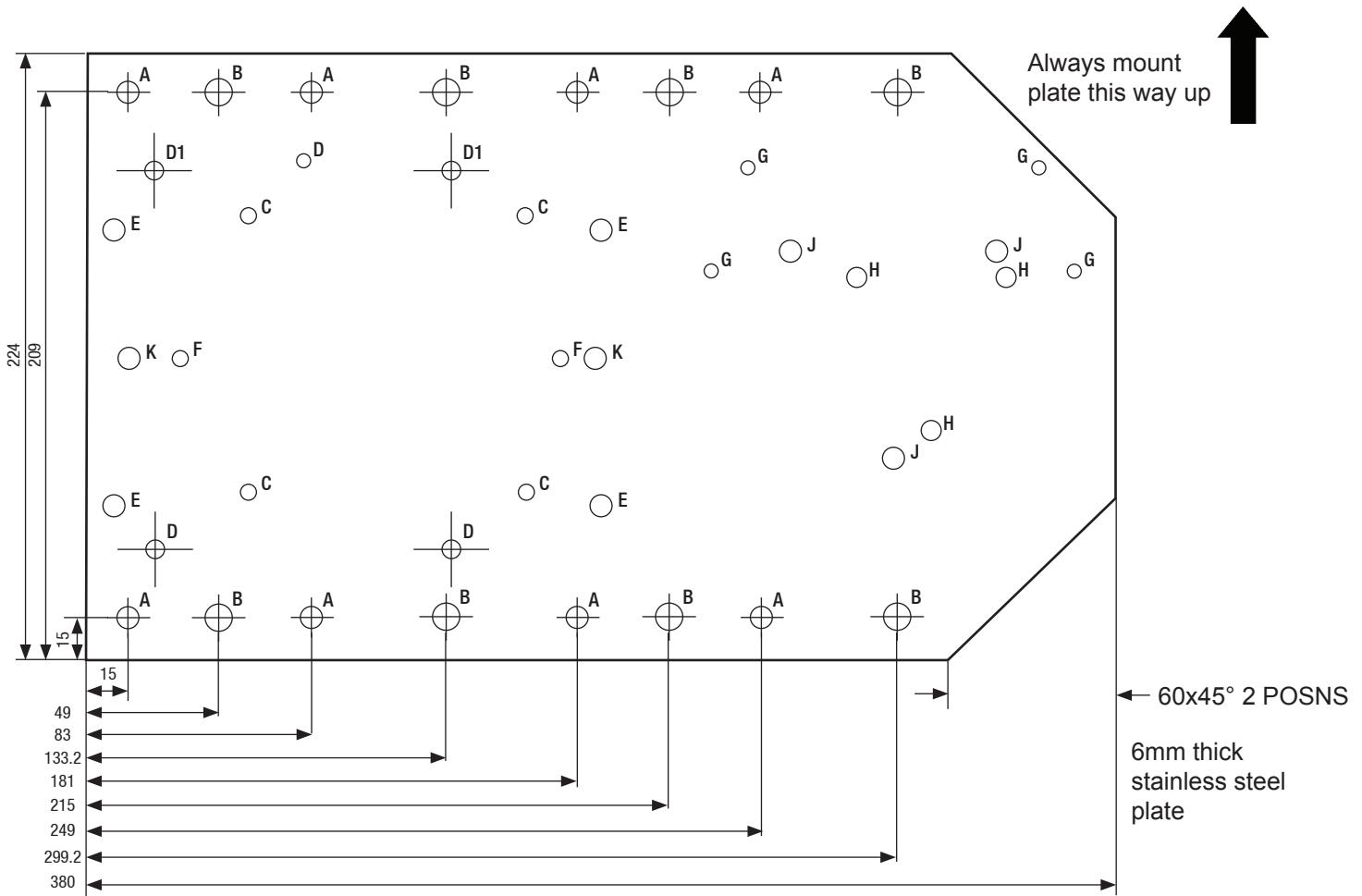

Notes:

1. Drawing is **not** to scale.
2. Mounting plate fixing holes are clear. Searchline Excel gas detector component mounting holes are tapped.
3. The mounting plate fixings are not supplied.

Identity	Quantity	Size	Used For
A	8	Ø7.5mm	Dual 2" pipe or pole mounting, flat surface mounting.
B	8	Ø9.5mm	Single 6" pole, flat surface mounting, Dual 2.5" ID pipe.
C	4	M6 tapped	00780-A-0100 junction box mounting

3. INSTALLATION AND OPERATION

D	3	M6 tapped	DVC100(M) junction box mounting.
D1	2	M6 tapped	DVC100 (M) MK2 junction box (used in conjunction with bottom two D holes)
E	4	M10 tapped	DX100(M) junction box mounting.
F	2	M6 tapped	Killark/Akron junction box mounting.
G	4	M6 tapped	Sun/heat shade mounting.
H	3	M8 tapped	Short range Transmitter and all Receiver brackets.
J	3	M10 tapped	Medium/Long range Transmitter mounting bracket.
K	2	M10 tapped	XNX Universal Transmitter

The following drawings show typical mountings:

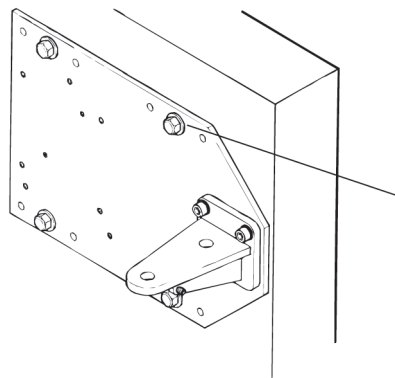

M8 mounting bolt - 4-off
(not supplied) using **B** holes

Mounting Plate Fixed to Flat Surface

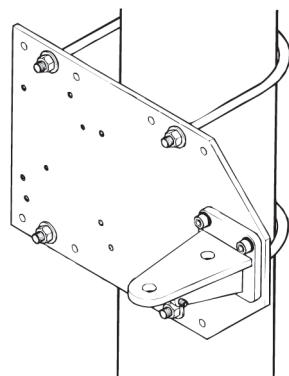

6in. U-bolt - 2-off
(not supplied) using **B** holes

Mounting Plate Fixed to Single Pipe/Pole

3. INSTALLATION AND OPERATION

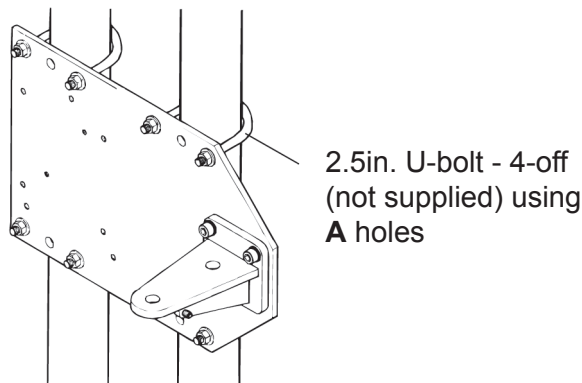

Mounting Plate Fixed to Twin Pipes/Poles

- (4) Fit an adjustment clamp to the unit's pivot block mounting stud so that it sits on the stud's shoulder. The correct orientation for the pivot blocks and clamps is as follows:

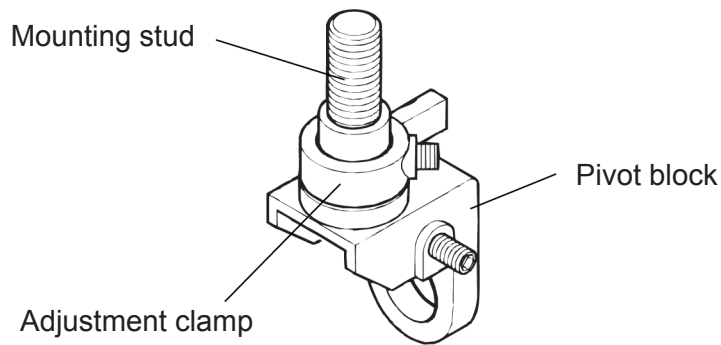

- (5) Tighten the adjustment clamp's grub screws until they just grip the unthreaded part of the stud.
- (6) Fit the pivot block to the mounting bracket using a clamp nut and washer (M12 or M16). The correct orientation for the pivot blocks and mounting brackets is as follows:

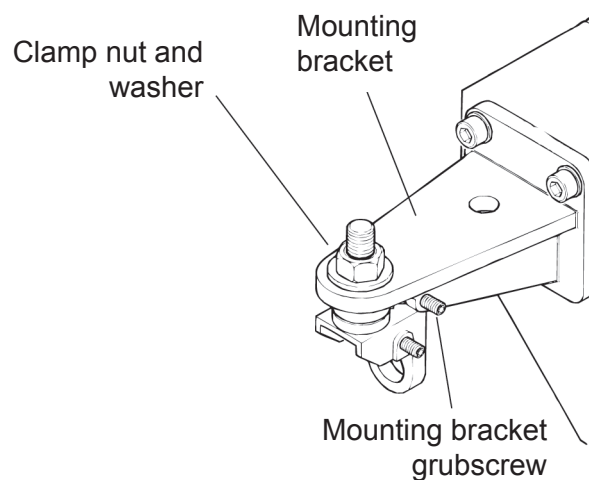

Do not fully tighten the nut (Refer to 3.73).

3. INSTALLATION AND OPERATION

Ensure that the adjustment clamp's stub lever is approximately centrally positioned between the mounting bracket's grub screws. Adjust the screws if required.

- (7) Fit an adjustment clamp to the unit's mounting stud so that it sits on the stud's shoulder. The correct orientation for the adjustment clamp is as follows:

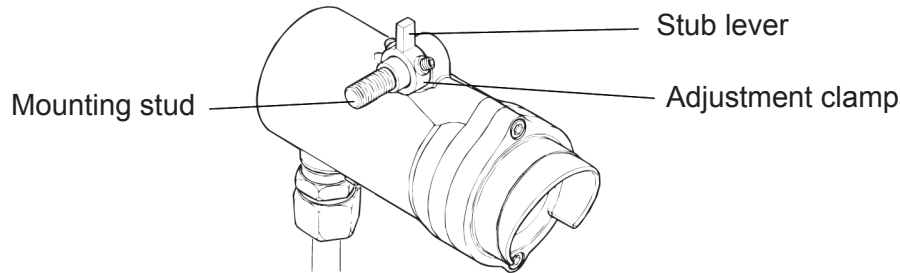

- (8) Tighten the adjustment clamp's grub screws until they just grip the unthreaded part of the unit's mounting stud.
- (9) Fit the unit to the pivot block using a clamp nut and washer (M12 or M16).

Do not fully tighten the nut (Refer to 3.73).

At this point position the units on their mountings so that their optical windows face each other as shown:

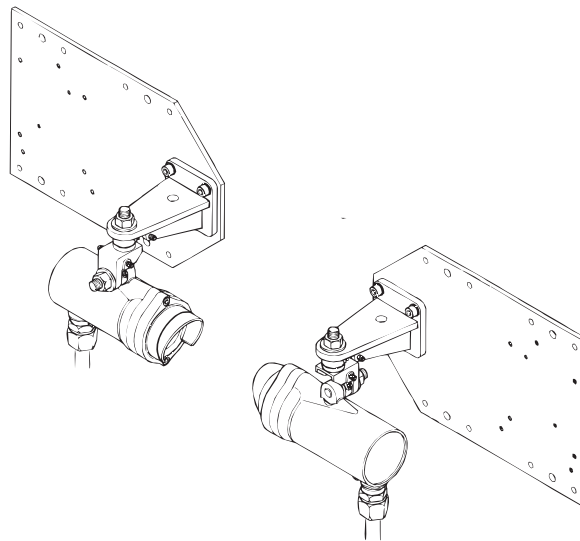

Ensure that the adjustment clamp's stub lever is approximately centrally positioned between the pivot block's grub screws. Adjust the screws if required.

- (10) Fit a suitable junction box, e.g. DX100(M) or other suitable type of junction box, to the mounting plate. A typical installation with junction boxes is as follows:

3. INSTALLATION AND OPERATION

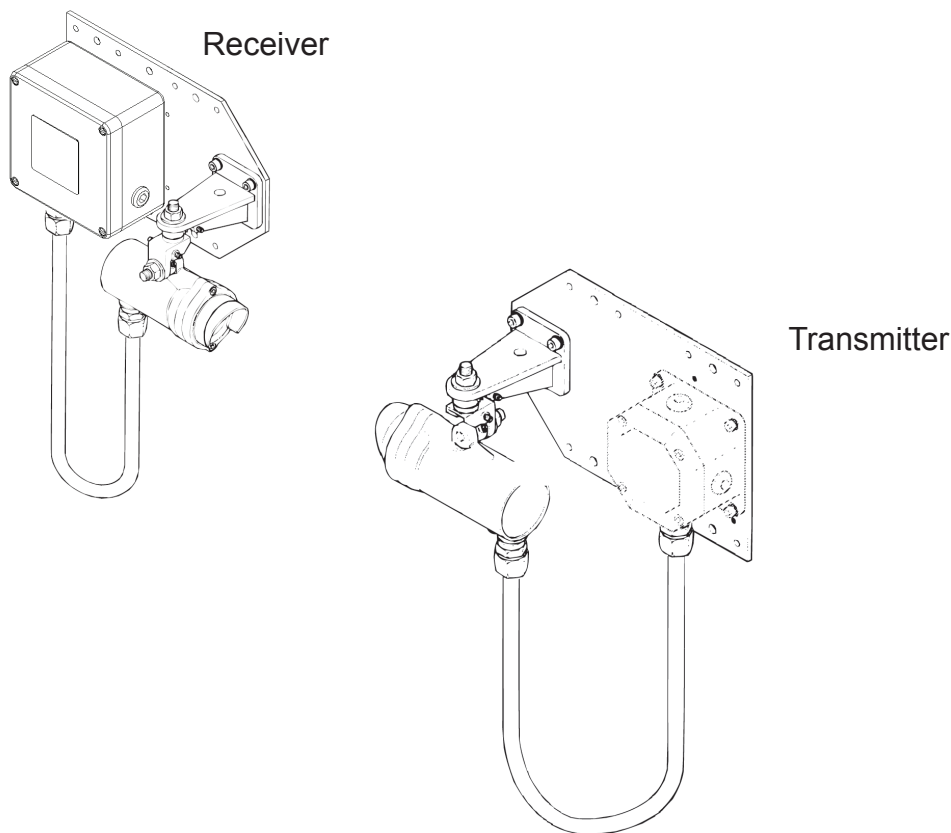

Note: For information about alternative types of junction box see section 3.6.2 Electrical Installation.

- (11) Measure and record the distance (in metres) between the Transmitter and Receiver units.

This distance is required later in the alignment procedures.

3.6.2 Electrical Installation

- (1) Isolate all associated power supplies and ensure that they remain **OFF** until the instruction in the commissioning procedure to apply power.

See section 3.7 Alignment and Commissioning. If the units are to be installed with junction boxes other than DX100(M) or OELD types, ensure that the boxes have:

- a. *M20 cable gland entries for ATEX/IECEX units, or 3/4 NPT for UL and CSA/FM*
 - b. *terminals for five wires and an earth.*
- (2) Remove the M20 blanking plugs (if fitted) and attach the Searchline Excel Transmitter and Receiver cables to their junction box.
Fit the locking rings (if supplied) before terminating the cables in the junction box.
 - (3) Fit approved cable glands to the junction box cable entries.
Use sealing washers where necessary to maintain the ingress protection rating.
 - (4) Fit approved blanking plugs to all unused cable entries.
 - (5) Make electrical connections.

See section 3.3.

3. INSTALLATION AND OPERATION

3.7 ALIGNMENT AND COMMISSIONING

WARNING

Do not attempt to view the Sun through the optical telescope.

3.7.1 General

In order to avoid unnecessary problems, alignment and commissioning of Searchline Excel gas detectors should only be performed by personnel trained by Honeywell Analytics.

To ensure optimum performance the gas detector Transmitter and Receiver units must be accurately aligned with a clear line of sight between them.

The Transmitter unit is first aligned with the Receiver using a telescope attached to the body of the unit. A telescope is then fitted to the Receiver and the alignment procedure repeated.

The Handheld Interrogator is then attached to the Receiver to finally commission the equipment and, depending on the type of Receiver, may need to be used to assist in fine-tuning the alignment.

The procedure can be performed by a single technician.

Each gas detector unit features a mounting assembly that allow both coarse and fine mechanical adjustment in the horizontal and vertical directions as shown in the subsequent diagram.

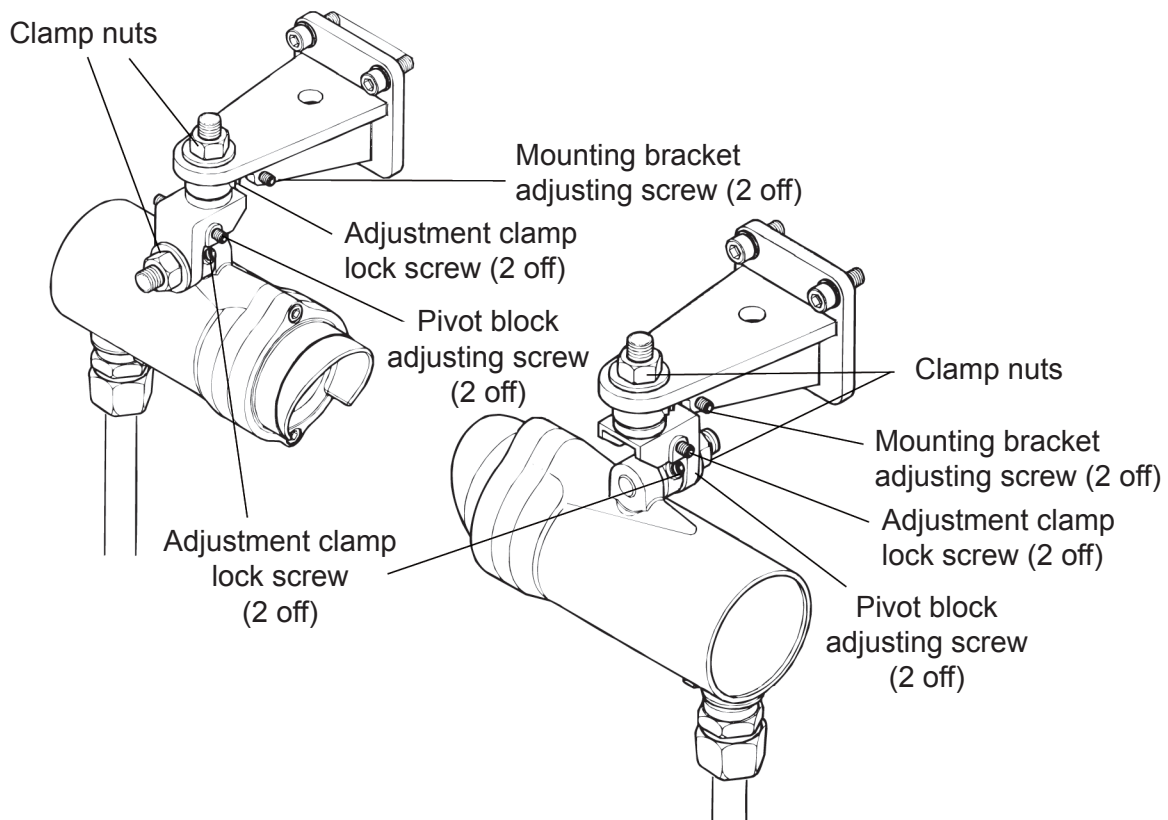

Initial coarse mechanical adjustment is first carried out by means of large clamping nuts and with the help of an alignment telescope.

3. INSTALLATION AND OPERATION

Fine adjustment is then achieved by means of mounting bracket and pivot block grub screws which move levers on the adjustment clamps, fitted to the pivot block and unit studs, and hence the unit.

After initial mechanical setup the units are powered up and the mechanical alignment can be optimised and verified electronically by means of the associated Handheld Interrogator linked to the Receiver.

By entering the operating range of the gas detector the Interrogator then provides reassurance that the alignment has been performed successfully. The gas detector cannot be put into service until it is.

The following equipment is used to carry out the alignment and commissioning:

- Alignment Telescope(s) suitable for the distance between the units (see **Appendix C - Accessories & Spare Parts**).
- SHC1 Handheld Interrogator (see Appendix C - Spare Parts).
- Optional SHC Protection Device (see **Appendix C - Accessories & Spare Parts**) - see Note 8.
- Appropriate plastic test filters (see **Chapter 5**, section 5.1.2).
- 3mm hex (Allen) key.
- 19mm spanner (with additional 24mm spanner for mid/long range gas detectors).

Notes:

1. *Ideally, carry out the alignment procedure on a clear day.*
2. *Get familiar with the workings of the adjustable parts of the gas detector before proceeding with the alignment procedure, see section 3.7.4.*
3. *The alignment telescopes use the same datum used when the unit was aligned in the factory to ensure precise field alignment.*
4. *The telescopes incorporate eye relief adjustment for comfortable viewing.*
5. *Keep telescope mirrors and optics clean.*
6. *Do **not** try to adjust the cross-hairs using the telescope's elevation and windage adjusters as they have been factory set.*
7. *If a telescope is damaged or misaligned it will need to be returned to the factory for repair or realignment.*
8. *The SHC Protection Device is only required if connecting the SHC1 Handheld Interrogator via a junction box other than a or DX100(M).*

3. INSTALLATION AND OPERATION

3.7.2 Alignment Procedure

The following summarises the alignment procedure:

- **Basic gas detector alignment, see section 3.7.3.**
- **Accurate alignment of Transmitter and Receiver using the appropriate alignment telescope, see section 3.7.4.**
- **Power-up and verify alignment using SHC1 Handheld Interrogator linked to the Receiver, see section 3.7.5.**

3.7.3 Basic Gas Detector Alignment

The basic procedure for aligning the Transmitter and Receiver units is the same.

- (1) Loosen the two clamping nuts and four adjustment clamp screws on the Transmitter and Receiver units until the units move freely in all axes.
- (2) Point the Transmitter and Receiver units so that they face each other across the area to be protected.
- (3) Tighten the clamping nuts and adjustment clamp grub screws on each unit until the unit cannot be moved by hand.

This is the last time that these clamp nuts and grub screws should need to be tightened. Further tightening later on will affect the fine adjustment and should be avoided.

Note: The unit can still be moved by the adjustment screws.

3.7.4 Accurate Alignment

The procedure for accurately aligning the Transmitter and Receiver units is the same.

Before making any adjustments consult the following table to ensure that the correct type of telescope is used with the Excel units that are to be aligned.

Excel Type	Type of <i>Trident</i> telescope that can be used	SHC1 Handheld Interrogator required to finalise alignment?
Trident Excel	Latch-type	No
	Bayonet-type	No
Non-Trident Excel	Latch-type	Yes

To tell the difference between the two types of Excel look at the front face of the units. The Trident-type Excel units have three small pads on their front face, the non-Trident types do not.

These pads provide three contact points (hence the term Trident) for the alignment telescope assembly datum mount to ensure accurate fixing of the telescope so that subsequent alignment of the gas detector units is precise.

The following diagrams illustrate the differences.

3. INSTALLATION AND OPERATION

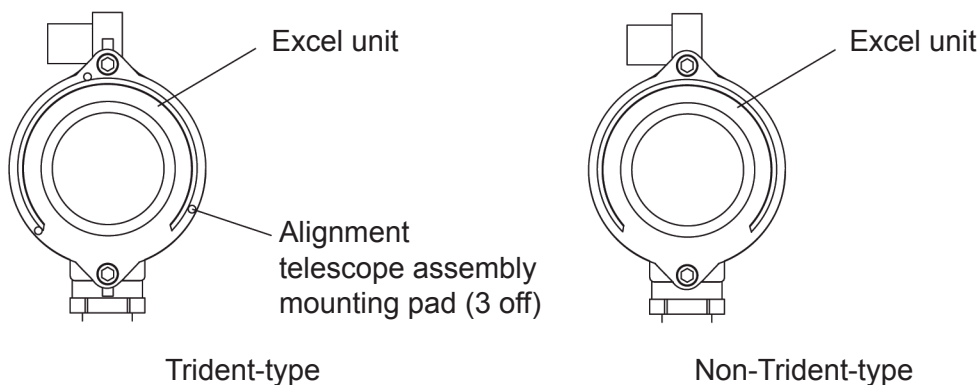

After deciding from the table which alignment telescope to use for the Excel units being aligned the telescope assembly must be fitted to each of the units in turn starting with the Transmitter. There are two ways of attaching the telescope to the Excel units - using latches or using a bayonet fitting. Depending on the type supplied refer to the relevant procedure described subsequently.

The bayonet style telescope is used on both the Transmitter and Receiver of the short range Excel. The bayonet-style telescope is also used on the Receiver of the medium and long range Excels. The latch-style telescope is used on the medium and long range Excel Transmitters.

Latch-style telescope assembly

This telescope assembly consists of a telescope and mirror assembly attached to a datum mount that features a latching mechanism. It can be used with either the Trident or non-Trident types of Excel units.

When used with the non-Trident Excel the alignment may also need to be fine-tuned and then verified using the SHC1 Handheld Interrogator.

The latches are used to lock the whole assembly onto the body of the Excel unit.

Before securing the latches the telescope can be rotated to a convenient viewing position.

To remove the telescope assembly reverse the following fitting procedure.

- (a) Fit the datum mount of the alignment telescope securely over the cowl of the unit as shown so that the face of the mirror is visible.

Ensure the datum mount is fully home on the cowling.

- (b) Undo the latches on the alignment telescope's mounting latch assembly and rotate the assembly so that the parallel support bar fits underneath the unit as indicated by arrow 2.

3. INSTALLATION AND OPERATION

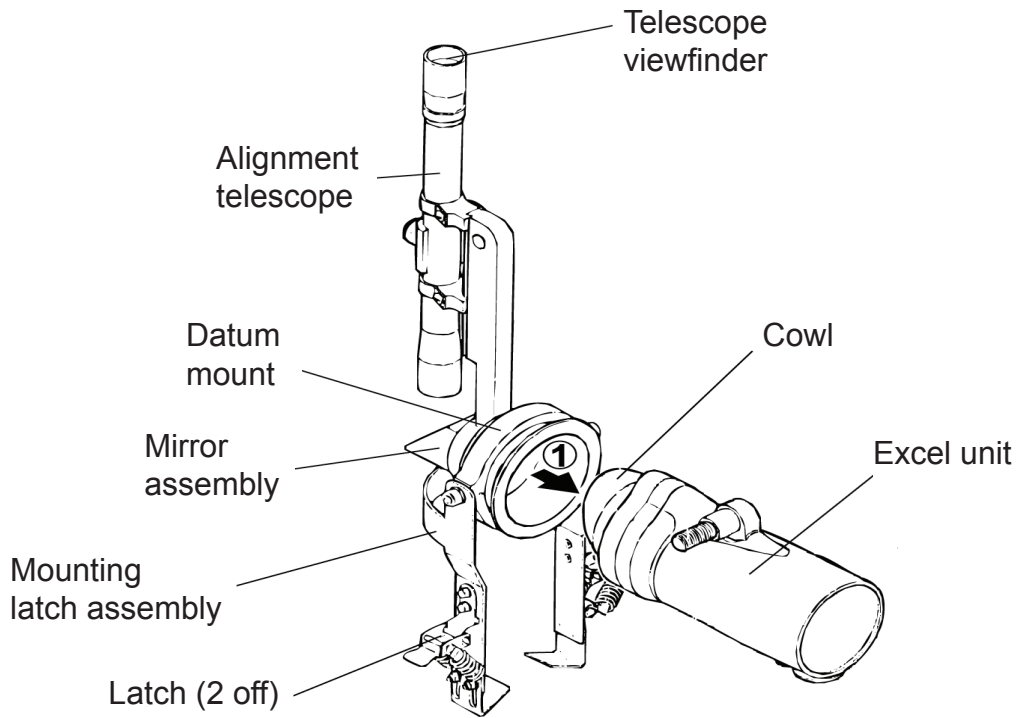

- (c) Locate the latch mounting hooks behind the back of the unit.

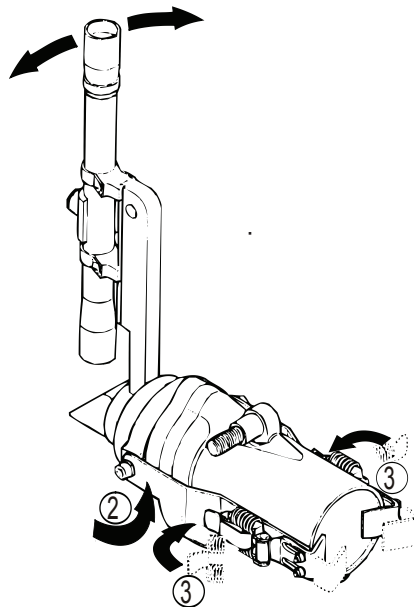

- (d) Rotate the telescope to a comfortable viewing position, and then secure the latches as indicated by arrow 3.

A horizontal viewing position is the easiest to interpret.

Now align the units by continuing with step 5.

Note: Take care when undoing the latches to remove the alignment telescope not to touch the springs.

3. INSTALLATION AND OPERATION

Bayonet-style Trident-type telescope assembly

Caution: *This type of telescope assembly must only be used with Trident-type Excel units.*

This type of telescope assembly consists of a telescope and mirror attached to a datum mount. The mount features a bayonet fitting for attaching the assembly to the Excel unit.

The datum mount has a handle for rotating and locking the whole assembly over the cowl and onto the Excel unit's body.

Before tightening the datum mount the telescope can be rotated to a convenient viewing position.

To remove the telescope assembly reverse the following mounting procedure.

- (a) Align the telescope's two datum mount bayonet slots with the two locating pins on the cowl of the unit as shown.

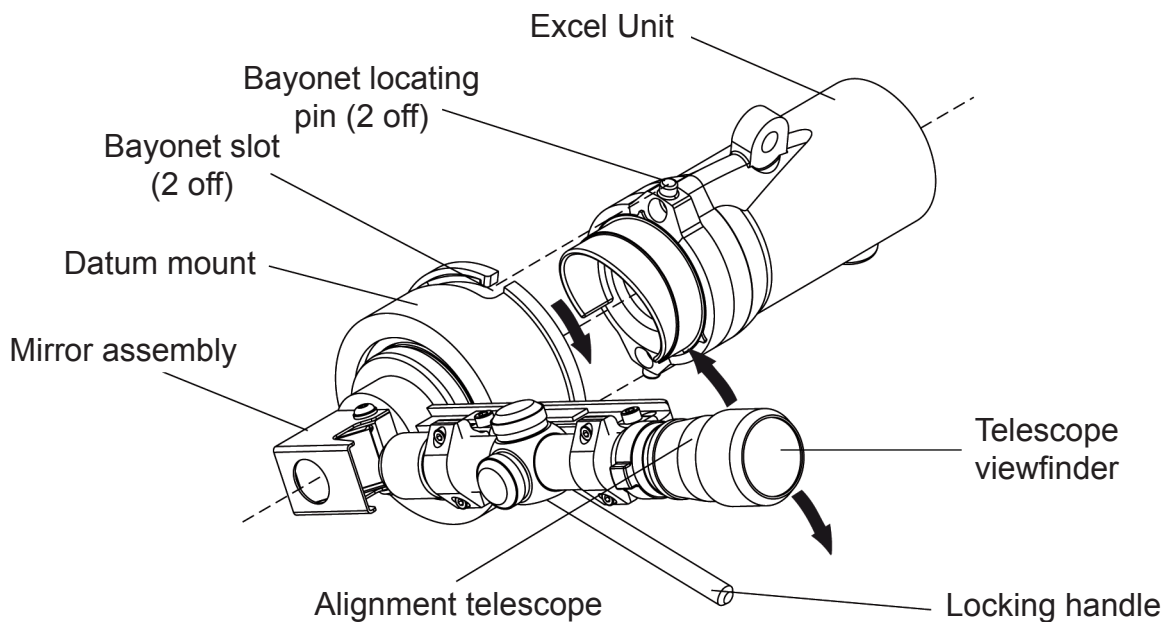

- (b) Push the telescope datum mount fully home onto the two pins on the cowl.
- (c) Without disturbing the datum mount use one hand to rotate the telescope to a comfortable viewing position and hold it in that position.

A horizontal viewing position is the easiest to interpret.

3. INSTALLATION AND OPERATION

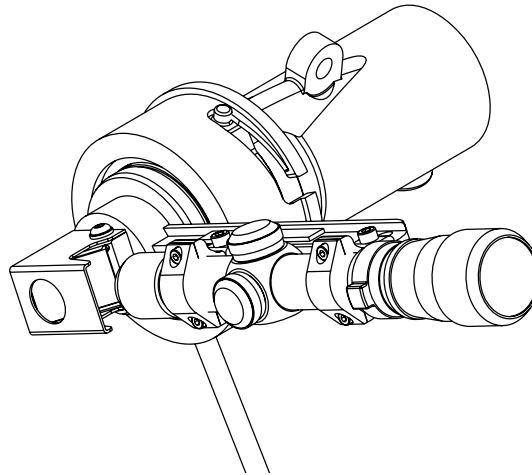

- (d) With the other hand use the datum mount's locking handle to rotate the bayonet fitting in a clockwise direction until it is securely locked onto the cowl.
The fitting is held tightly against the face of the cowl by means of hidden compression springs.

After attaching the telescope assembly align the units by continuing with step 5.

- (5) Align the Excel unit using the two sets of assembly adjustment screws so that the cross-hairs viewed through the alignment telescope are centred on the window of the other Excel unit.

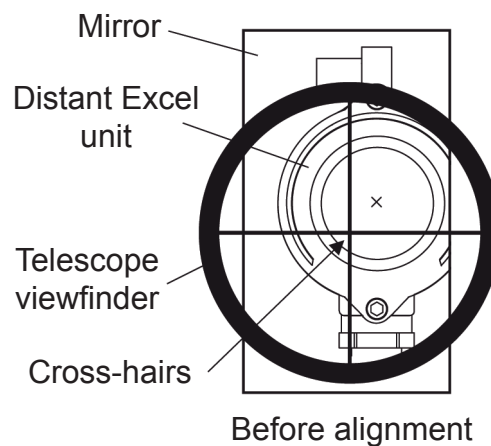

View the image with the eye placed approximately 3 inches from the viewfinder.

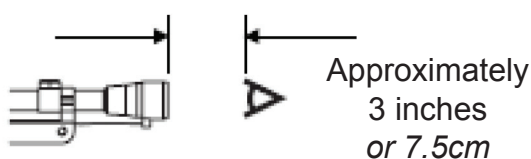

3. INSTALLATION AND OPERATION

Use a viewing position that ensures that the full circular view is in sight. An ellipse will appear when slightly off axis.

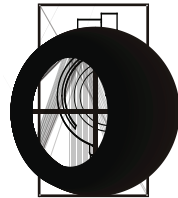

Off-axis view

Caution: Do not try to adjust the cross-hairs using the telescope's elevation and windage adjusters as they have been factory set.

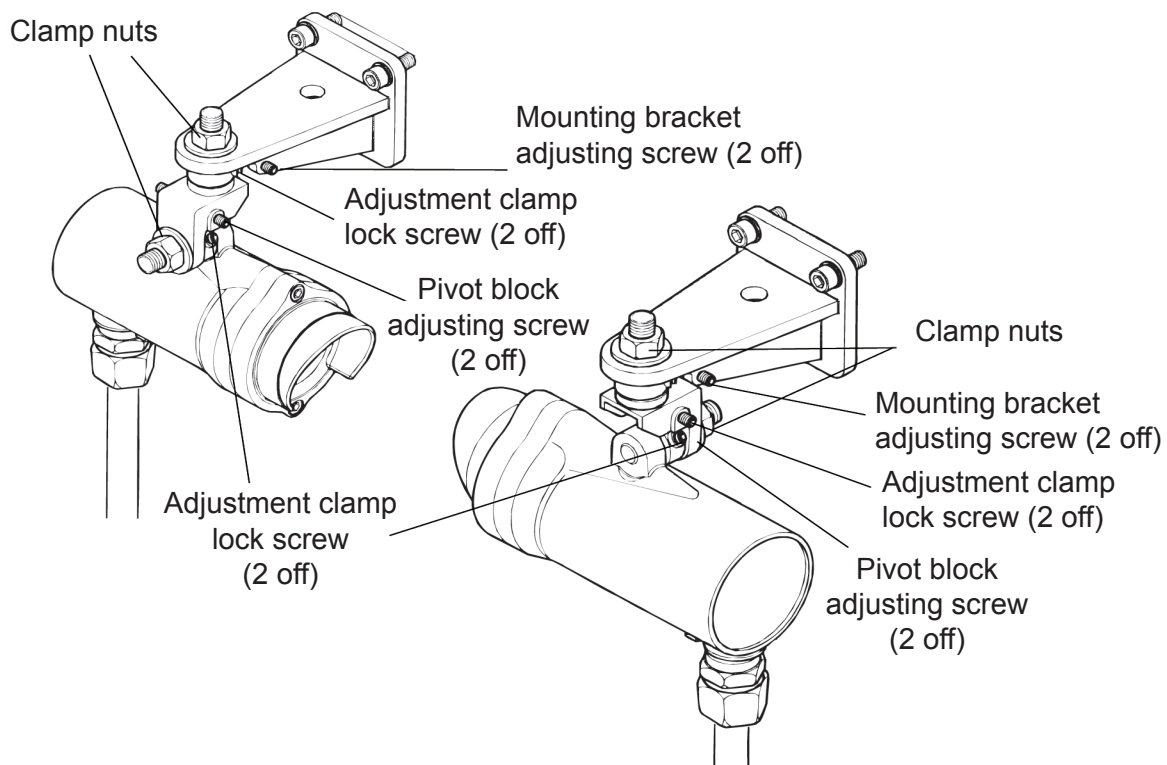

- (6) Tighten and loosen each pair of adjustment screws sequentially in the horizontal and vertical directions until the setting is correct.
- (7) When correctly adjusted, tighten both adjustment screws simultaneously. Ensure there is minimum movement whilst locking the assembly.
- (8) Check alignment and repeat steps 5 to 7 as necessary.
- (9) Remove the telescope assembly from the unit by reversing the fitting instructions.
- (10) Carry out the final commissioning procedures described in the next sub-section.

3. INSTALLATION AND OPERATION

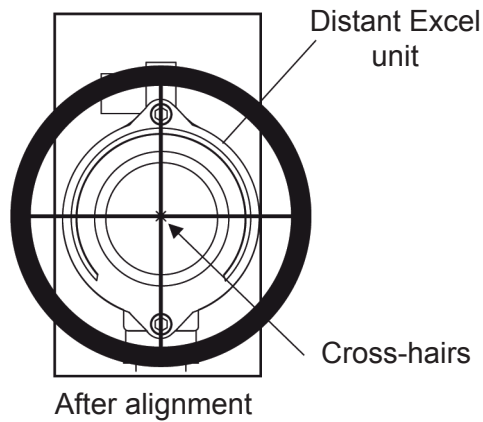

3.7.5 Commissioning the Gas Detector

This process consists of the following steps:

- **Connect the Handheld Interrogator to the gas detector**
- **Power-up the gas detector and check/set the mode of the Interrogator for operation with the installed Excel gas detector**
- **Set the gas detector real-time clock**
- **Complete the alignment process**
- **Finish up**

Connecting the Interrogator

Connect the SHC1 Handheld Interrogator to the gas detector in one of the following ways:

- via a Honeywell Analytics DX100(M) Junction Box - connect the Interrogator directly to the junction box via its IS socket, e.g.

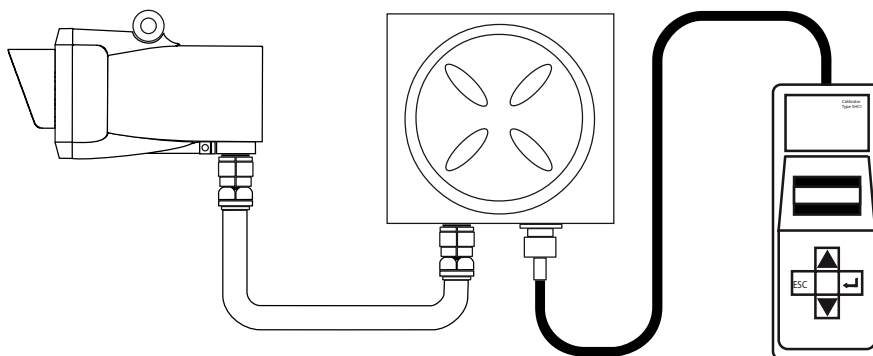

3. INSTALLATION AND OPERATION

- via the OELD Smart Junction Box or another type of junction box, e.g. Honeywell Analytics Junction Box Part Number 00780-A-0100 - using the SHC Protection Device.

See the following diagram and description and **Appendix C - Spare Parts**.

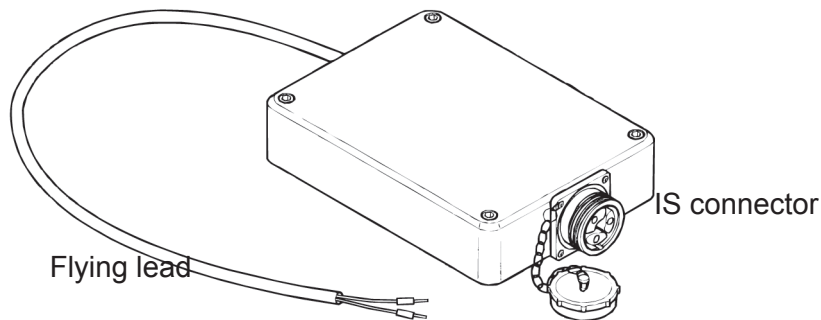

Notes:

- The protection device must always be used for this type of connection.
- A hot work permit may be required for this procedure.

Carry out the following procedure to connect using the protection device.:

- Isolate all power supplies.
- Remove the cover of the junction box.
- Hard wire the flying lead of the SHC Protection Device to the communications link terminals in the box as shown:

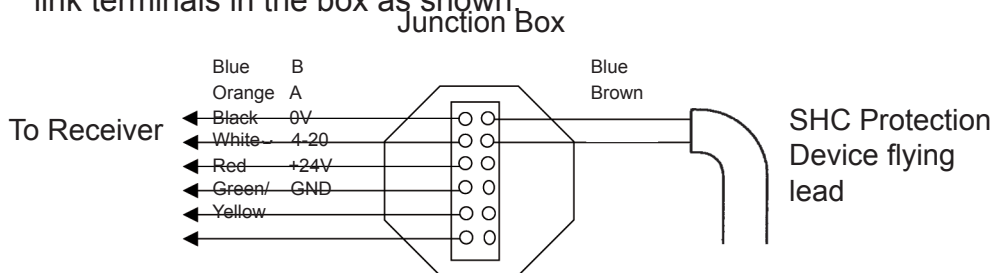

- Connect the Interrogator to the IS connector on the end of the SHC Protection Device.

Powering Up

- Apply power to the Excel Transmitter and Receiver units.
- Press and hold the **↵ (Enter)** key on the Interrogator keypad for at least two seconds.

3. INSTALLATION AND OPERATION

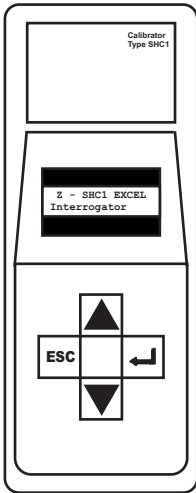

*This section is only relevant to handheld software versions 4V0 and greater.
This switches on the unit.*

Note: Full details of the SHC1 Handheld Interrogator can be found in Appendix A.

The Interrogator displays the following start-up message for approximately three seconds:

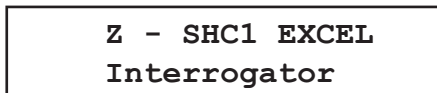

- (3) Quickly check the type of connected detector shown on the top line of the message.
*The display shows **Excel** or **Optima+** or **Optima**.*
- (4) If the unit displays **Optima+** or **Optima** immediately press the **ESC** key on the keypad.

*The **ESC** key must be pressed within 3 seconds to have any effect. Also see Appendix A, section 5.6.*

*This toggles the Interrogator mode between **Excel**, **Optima Plus** and **Optima**.*

*The start-up message is updated and displayed again for 3 seconds then the unit displays the **Main** menu, which is the top level of its Interrogator's menu style interface, as follows:*

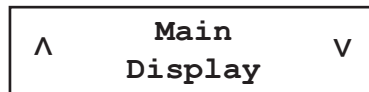

The first line of the display shows the current level in the menu tree and the second line displays a sub-menu title, action or data.

Setting the Real-Time Clock

The gas detector clock needs to be initially set so that faults, events, etc., can be accurately recorded and tracked for diagnostic purposes.

- (1) Select **Calibrate** from the **Main** menu by pressing the ▲ (**up**) and ▼ (**down**) keys on the keypad to navigate through the menu options.
- (2) Press ↵ (**Enter**) on the Interrogator keypad to display the **Calibrate** menu.
- (3) Select **Set Time/Date** from the **Calibrate** menu.

3. INSTALLATION AND OPERATION

- (4) Press **Enter** on the keypad and an initial set time display similar to the following appears:

^	Time 09:26	v
	09	

The top line shows the current time and the second line shows the new hours setting.

- (5) Set the hour using the up and down keys on the keypad.
- (6) Press **Enter** on the keypad and the new minutes setting is now displayed on the second line.

^	Time 09:26	v
	09:26	

- (7) Set the minutes using the up and down keys on the keypad.
- (8) Press **Enter** on the keypad and the display for setting the date now appears as follows:

^	Date 20APR03	v
	20	

The second line shows the new day setting.

- (9) Set the day using the up and down keys on the keypad.
- (10) Press **Enter** on the keypad and the new month setting is then displayed.
- (11) Repeat the procedure to set the month and year.
- (12) When complete press **Enter** on the keypad to return to the **Calibrate** menu.

Notes:

1. *The time and date will not be updated unless both are entered and accepted without error.*
2. *Pressing **ESC** on the keypad at any time, aborts the current setting immediately and returns to the previous setting or menu option.*

Complete the alignment process

In this part of the procedure details about the gas detector must be entered so that the Interrogator can then complete the commissioning of the gas detector using the correct data.

- (1) Select **Calibrate** from the **Main** menu.
Press the up and down keys on the keypad to navigate through the menu options.
- (2) Press **Enter** on the Interrogator keypad.
*This displays the **Calibrate** menu.*
- (3) Select **Install** from the **Calibrate** menu.
- (4) Press **Enter** on the keypad.

3. INSTALLATION AND OPERATION

The following is displayed:

```

System Type
Shrt Range
    
```

The second line shows the current gas detector type:

```

Short Range      5 - 40m      (15 - 130ft)
Medium Range    40 - 120m     (130 - 390ft)
Long Range     120 - 200m    (390 - 650ft)
    
```

- (6) Press **Enter** on the keypad.

The current path length setting in metres similar to the following is now displayed.

```

Path Length
^      nnnn      v
    
```

- (7) Set the actual path distance (measured in metres) between the Transmitter and Receiver units, using the up and down keys on the keypad.

The minimum and maximum path length entry options for each gas detector are:

System Type	Minimum Range (m)	Maximum Range (m)	Step Size (m)
Short Range	5	40	1
Medium Range	40	120	1
Long Range	120	200	1

- (9) When finished press **Enter** on the keypad.

A self-test routine is started and the display shows the following message:

```

Self Test
Please Wait
    
```

When the test is successfully finished the following message is displayed for at least three seconds:

```

Checks Passed
    
```

The screen then changes to show a display similar to the following.

```

SIG: ■
TGT: ■■
    
```

Note: If this screen shows a numerical value the alignment is not sufficient. Refer back to 3.72.

The first line of the display shows the magnitude of the current **signal** level as a horizontal bar graph - **SIG**:

3. INSTALLATION AND OPERATION

The second line of the display shows the magnitude of the current **target** signal level as a horizontal bar graph - **TGT**:

Important Notes:

- 1) The overall objective of alignment is to maximise the **SIG** level. Maximised **SIG** corresponds to optimal alignment.
 - 2) The Instrument Assisted Alignment (IAA) system only allows Excel to be initialised if the **SIG** level is greater than or equal to the **TGT** level when **Enter** is pressed.
 - 3) The smallest **TGT** signal level that is initially set will be equivalent to 70% (0.700) of the signal expected for the installation's path length.
 - 4) The **TGT** level will increase gradually if the current **SIG** level is larger than the **TGT** level. The **TGT** signal level only ever increases. If the current **SIG** level falls below the **TGT** level, **TGT** will remain at its previous highest value. In order to initialise the gas detector the **SIG** level must be brought back above the **TGT** level.
 - 5) If the **SIG** level is less than 50% of the expected level, the bar graphs are **not** displayed. Instead both **SIG** and **TGT** levels are displayed as numbers.
- (10) Now carry out one of the procedures described under **Options**.

Options

The next procedure to be followed depends on the type of alignment telescope and mounting initially used to set up the Excel gas detector.

Bayonet-style Trident-type telescope assembly

If this type of alignment telescope was used with a Trident-type Excel gas detector, there is no need to further optimise the alignment using the SHC1 Handheld Interrogator.

When the **SIG** and **TGT** bar graphs are displayed on the SHC1 screen, **SIG** will always be greater than **TGT** and installation can proceed to the next stage by pressing **Enter** and following step 12.

Latch-style Trident-type telescope assembly

If this type of alignment telescope was used with a Trident-type Excel gas detector, there is no need to further optimise the alignment using the SHC1 Handheld Interrogator.

If this type of alignment telescope was used with a non-Trident Excel it may be necessary to further optimise the alignment in the following way in order to achieve best performance.

- (a) After the **SIG** and **TGT** bar graphs are displayed on the SHC1 screen as previously described, let the **TGT** level reach its initial maximum by waiting for approximately 10 seconds.

*During this time the **TGT** level will move up towards the current **SIG** level.*

- (b) Whilst watching the **SIG** level closely, make a **small** mechanical adjustment in either the horizontal or vertical alignment and note whether the **SIG** level goes up or down.
- (c) If the **SIG** level goes **up**, make another **small** mechanical adjustment in the same direction as before.

3. INSTALLATION AND OPERATION

- (d) If the **SIG** level goes **down**, change the direction of adjustment.
*Maximise the **SIG** level by making **small** adjustments in only **one plane** at a time.*
- (e) When the **SIG** level has been maximised in one plane, make small adjustments in the other plane until **SIG** has been maximised in this plane.
- (f) Repeat steps (b) to (e) until the **SIG** level has been maximised in both planes.
*At this point, **SIG** must be bigger than the initial **TGT** level and any adjustment either side of the current alignment must result in a reduction in signal level.
If not, repeat steps (b) to (e) until these requirements have been met.*
- (g) Lock off the alignment by placing a hex (Allen) key in the pair of grub-screws which control adjustment in a particular plane and simultaneously rotating them in opposite directions.
- (h) Repeat this for the other pair of grub-screws.
- (i) Press **Enter** and the signal levels are checked.

*With the **SIG** level is greater than the **TGT** level, the signal check should pass and the screen should display the following message:*

Signals OK

Notes:

1. If **SIG** is less than the **TGT** value the following message is displayed:

Low Signal
Enter to Retry

2. If **SIG** is more than the **TGT** value the screen shows the bar graph screen again.

- (12) When the following message is displayed press Enter:

Signals OK

The display changes to show the following instruction:

Ensure Zero Gas
Then Press Enter

Ensure there is a gas-free atmosphere.

- (13) Press **Enter** on the keypad.

The following message is displayed for three seconds:

Zero Calibration
OK

3. INSTALLATION AND OPERATION

The following message is displayed for three seconds:

Installation
Complete

The following message is then displayed:

Press Enter to
Release 4-20

- (14) Press **Enter** on the keypad.

The following message is displayed for three seconds:

4-20 Released

The display then changes to show the **Calibrate** menu. The Searchline Excel gas detector is now **on-line**.

This completes the final part of the gas detector alignment procedure.

3.7.6 Finishing Up

To finish the alignment process carry out the following procedure:

- (1) Select **Power Off** from the Interrogator **Main** menu.
- (2) Press **↵** (**Enter**) on the keypad.
*Alternatively press the **↵** and **ESC** buttons simultaneously for a fast power off.*

Notes:

1. The SHC1 Handheld Interrogator powers down automatically after five minutes of non-use.
2. Fast power off and auto power off are disabled when any menu option is selected that modifies the unit's configuration.
- (3) Disconnect the Interrogator from the gas detector, reversing the process described at the beginning of section **3.7.5**.

3.8 SYSTEM CONTROLLER CALIBRATION

This procedure is used to set up the system controller using the Searchline Excel gas detector. A chosen fixed output signal is sent from the Excel gas detector to the system controller allowing calibration of the 0 - 100% scale of the controller without having to use gas. The steps use procedures described in the previous section.

To calibrate the controller carry out the following procedure:

- (1) Connect the Interrogator to the gas detector.
*See **Connecting the Interrogator to Searchline Excel Gas Detector**.*
- (2) Turn on the Interrogator.
*See **Powering Up**.*
- (3) Select **Calibrate** from the main menu.
Press the up and down keys on the keypad to navigate through the menu options.

3. INSTALLATION AND OPERATION

- (4) Press **Enter** on the Interrogator keypad and the **Calibrate** menu is displayed.
- (5) Select **Force 4-20** from the **Calibrate** menu.
- (6) Press **Enter** on the keypad and a display similar to the following appears:

^ 4-20 current v
4.5 mA

- (7) Use the up and down keys on the keypad to set the displayed output current to the desired value.
The values can be changed in steps of 0.1mA in the range 1mA to 21mA.
- (8) Press **Enter** on the keypad.
This selects the currently displayed value and forces the gas detector to output that current. Once complete a display similar to the following appears:

Fixed: 4-20 mA
Press Enter

- (9) Carry out checks on the controller by following the instructions in the controller documentation.
- (10) When checks are complete press ↵ on the Interrogator keypad and the following display appears:

Press Enter To
Release 4-20

- (11) Press **Enter** on the keypad.
The following message is displayed:

4-20 Released

The fixed output is released and the gas detector returns to normal operation.

- (12) Turn off the Interrogator and disconnect it from the gas detector.

3.9 INSTALLATION CHECKS/TESTS

The following information is for the guidance of personnel carrying out installation checks/tests on Searchline Excel. In general it should be noted that:

- Searchline Excel should only be installed by fully trained personnel, trained by Honeywell Analytics or an authorised Honeywell Analytics trainer.
- Detailed information concerning installation, alignment and commissioning is provided in this Technical Handbook.
- Searchline Excel is explosion protected by a certified, flameproof enclosure. Carefully read the safety warnings, cautions and certification details in this handbook and the Basic Installation Guide. Ensure that they have been complied with, before and during the installation.
- A copy of the subsequent **Installation Check Sheet** should be completed for each Searchline Excel gas detector installed. In order to help Honeywell Analytics to provide efficient assistance/service in the event of problems, the sheet should be returned to Honeywell Analytics or to one of their agents.

3. INSTALLATION AND OPERATION

SEARCHLINE EXCEL: INSTALLATION CHECK LIST							2104P1003	
CUSTOMER/OPERATOR								
SITE/FACILITY								
SYSTEM TYPE:	SR	MR	LR	OPERATING RANGE				
GAS TABLE:	METHANE	ETHANE	PROPANE	BUTANE	ETHYLENE	PROPYLENE	BUTADIENE	
	PENTANE	PROPYLENE	OTHER					
DETECTOR LOCATION:								
TAG NO. (RX):					TAG NO. (TX):			
SER NO. (RX):					SER NO. (TX):			
MOD STATE (RX):		MOD STATE (TX)		CERTIFICATION:				
CHECK/TEST		RECIEVER		CHECK/TEST		TRANSMITTER		
Mount Rigidity					Mount Rigidity			
Vibration:					Vibration:			
Excess Heat/Frost:					Excess Heat/Frost:			
Supply Voltage:					Supply Voltage:			
Earthing:					Earthing:			
RFI/EMC:					RFI/EMC:			
Contaminants:					Contaminants:			
BEAM OBSTRUCTIONS / BLOCKS:								
(cont.)								
TEST FILTER:		Response:		Pass:		Fail:		
4-20mA LOOP INTEGRITY		Pass:		Fail:		Untested:		
FAULT / WARNING LOG:		Clear:		Faults/Warnings:				
(cont.)								
INSTALLATION SATISFACTORY:		Yes:	No:	Signed:				
INSTALLED BY (PRINT)					DATE:			
IF INSTALLATION UNSATISFACTORY, REASONS								
RECOMMENDATIONS								
						CUSTOMER NOTIFIED:		
SYSTEM STATUS:	Operational:					Nonoperational:		

3. INSTALLATION AND OPERATION

The following notes are to help the installer enter the correct information onto the check sheet.

Site/Facility

Enter the name and geographical location of the site/facility, e.g.

NAM F3 Platform, North Sea

Operating Range

Enter the distance (preferably in metres), between the Transmitter and the Receiver.

Detector Location

Enter the location/position of the detector, e.g.

West Corridor, HIVAC Building1

Tag No

Enter the **Tag No**, or equivalent, that has been allocated to the Excel Receiver and Transmitter units.

Mod State

Enter the **Mod State** of the units as indicated on their certification/product labels.

Certification

Enter the certification of the units, e.g.

ATEX, UL, CSA, FM, IECEX

Mount Rigidity

Check that the units have been mounted securely to the supporting structure. Check that the supporting structure is sufficiently rigid to maintain alignment in the anticipated operating conditions. A maximum angular movement of $\pm 0.5^\circ$ is allowable.

As an approximate guideline, a sufficiently rigid mount/supporting structure will only move a few millimetres (not more than $\pm 6\text{mm}$) when leaning body weight against it.

When pushed hard and released, the mount/supporting structure should return quickly to its original position and should not wobble or sway. If the mount/ support is unacceptable, briefly describe the problem, e.g.

Mount wobbles unacceptably,

Mounting pole too thin

Vibration

Check the installation and its close surrounds for potential or existing sources of excessive vibration. Such sources could include heavy plant/machinery, turbines, generators etc.

3. INSTALLATION AND OPERATION

If there is the possibility that such vibration sources could or are causing unacceptable movement, enter a brief description, e.g.

***Turbine nearby,
Below conveyor***

Excess Heat/Frost

Check the installation and its surrounds for potential sources of excessive heat. Consider measures to be taken if frost build-up is very likely. The unit is specified to range between -60°C/+65°C. Excessive heat may include direct sunlight in hot climates, flare-stacks, generator/turbine exhausts and steam vents. Excessive frost build-up commonly occurs in very cold climate. Enter a brief description, e.g.

***Direct sun, Kuwait,
Flare-stack 2 metres away
or
Winter anti-cyclone, Siberia
Winter storm, Iceland***

Supply Voltage

Check that the supply voltage applied to the unit is within the specified 18V to 32V range and is stable. Enter the supply voltage and stability, e.g.

***22.5V, stable,
19V, ±2V fluctuation***

Earthing

Inspect the earth connections to the units. If the unit is connected to local metalwork or the safety/general use earth, enter 'Local Safety. If the unit has been isolated from local metalwork/ earths and is connected to a clean, ***instrument earth***, enter Instrument earth. (See section 3.3, Electrical Connections).

RFI/EMC

Assess the installation, cabling and its close surrounds for known/potential sources of excessive RF/Electromagnetic Interference. Such sources could include radio/radar transmission antennae, high voltage switch-gear, large electrical generators/motors etc.

Searchline Excel is extremely immune to RFI/EMI, complying with the most stringent requirements specified in EN50270. It is therefore more likely that the field cabling will pick up interference directly on the 4 - 20mA and 0V connections and that this will affect the reading received at the control room.

Enter brief details of known/potential EMI sources that are within five metres of the gas detector and/or its cabling. If cable is unscreened or inadequately protected, note concerns. Examples of the sort of information to enter are:

***10m cable, unscreened, Radar, 2m from Receiver,
Cable routed over 400kW generator***

3. INSTALLATION AND OPERATION

(See section 3.3 **Electrical Connections**).

Contaminants

Assess the installation and its surrounds for sources of contaminants that could build up on the unit's windows. Such contaminants could include oil mist, heavy sea spray, drilling mud, dirty exhaust fumes, wave splash etc.

If there is a realistic possibility that such contaminants could cause a significant problem, enter a brief description, e.g.

***Drilling mud spray,
Diesel generator exhaust***

Beam Obstruction/Blocks

Ideally, a clear path of at least **20cm** diameter should be provided between the Transmitter and the Receiver. Enter any obstructions which encroach into this path, e.g.

***Process pipes,
Tree branches***

Assess the installation and the beam path for potential sources of beam blockage. These could include personnel walking in the beam, parking vehicles, moving machinery/plant, growing vegetation etc.

If there is a realistic possibility that they could cause a significant problem, enter a brief description, e.g.

***Personnel in corridor,
Loading bay vehicles***

Test Filter

After completing the installation procedure, enter the **DISPLAY** mode and test the gas detector response with a plastic test filter. Enter the nominal value of the test filter, the unit's displayed response and mark the **Pass** or **Fail** box.

The acceptable responses to test filters for different gas tables are detailed in section 5.1.2.

4 - 20mA Loop Integrity

Test the 4 - 20mA loop integrity by forcing the unit to output a known current and monitoring this at the control room or with a multimeter inserted into the loop. Mark the appropriate box.

Fault/Warning Log

Check the fault/warning log. In order for the unit to complete installation satisfactorily, the **ACTIVE FAULTS** log must be **CLEAR**. Use the Handheld Interrogator to diagnose and remedy all **ACTIVE FAULT**.

Wherever possible, it is recommended to **CLEAR** any **ACTIVE WARNINGS**, since these may lead to faults in the future.

3. INSTALLATION AND OPERATION

Faults/Warning

Enter any ACTIVE FAULTS or ACTIVE WARNINGS that could not be cleared from the log, e.g.

**BEAM BLOCK,
E_ZERO_NOT_CALIBRATED**

Installation Satisfactory

Only fully trained personnel trained by Honeywell Analytics or Honeywell Analytics authorised trainers can declare an installation satisfactory. Mark the YES box and sign the form if:

- a. having completed the installation and testing, the unit is operating correctly, and
- b. in the trained installer's opinion, the unit should continue to operate reliably in this installation/ operating environment providing that nothing significant about the installation/environment is changed.

If the unit is not operating correctly or there are aspects of the installation/operating environment which in the trained installer's opinion could or will result in unreliable operation, mark the NO box.

Reasons for declaring an installation unsatisfactory could include:

***excessive movement/vibration of unit's mounting,
received signal levels too low,
supply voltage too low,
4 - 20mA loop integrity faults,
unclearable active faults,
any prevailing or probable condition which is known to unacceptably reduce
reliability or availability***

If Installation is Unsatisfactory, Reasons

Briefly state the principal reasons why the installation is unsatisfactory, e.g.

Unit mounted on single scaffold pole. Excessive movement,

***Beam path obscured by pipes, insufficient received signal levels,
Unit overheated by intense Kuwaiti sunlight***

Recommendations

Briefly describe the recommended actions which need to be performed in order to make the installation satisfactory, e.g.

***Mounting pole requires bracing/stiffening,
Pipes obscuring beam to be moved, or detector relocated.
Provide correct supply voltage***

Customer Notified

Make sure that the relevant customer/operator is notified of the installation problem(s). Mark box accordingly.

System Status

Upon leaving, note the gas detectors status, i.e. operational or nonoperational.

4. MAINTENANCE

The Searchline Excel Open-Path Gas Detector requires little maintenance other than occasional cleaning.

Depending on the local regulations and site conditions, cleaning and functional testing of the gas detector can be carried as described in the following sub-sections. The gas detector should remain powered during these procedures.

Caution: *Searchline Excel does not contain any user serviceable parts. Do not open either the Transmitter or Receiver unit. The warranty of units which have been opened is invalidated.*

NOTE: *THE INFRARED BEAM IS INVISIBLE AND EYE SAFE.*

4.1 INSPECTION AND CLEANING

Caution: *Do not use solvents or abrasives on the Searchline Excel units.*

- (1) Inspect the Searchline Excel units, junction box and cabling for signs of physical damage.
- (2) Using the SHC1 Handheld Interrogator inhibit the Searchline Excel signal output.
*Since the signal output may vary during cleaning, due to the optical path being disturbed, it is important to inhibit the analogue output. The quickest way to inhibit the Excel output is to select **DISPLAY** from the **Calibration** menu.*
- (3) Clean any dust or dirt from the Searchline Excel windows using soapy water and a soft cloth.
- (4) Using the SHC1 Handheld Interrogator release the Searchline Excel signal output.
*The output can be released by pressing **ESC** followed by **↵** on the keyboard.*
- (5) Using the SHC1 Handheld Interrogator re-zero the unit.
*See **Appendix A** for details about how to use the Interrogator.*

4.2 SEARCHLINE EXCEL: PLASTIC FUNCTIONAL TEST FILTERS – OPEN PATH

These filters have been specifically designed to work with open-path Excel units of Mod state 7 or higher.

4.2.1 Functional Testing of Open Path Searchline Excel Units

Note: Refer to the test sheet that was supplied with the Searchline Excel receiver for the original filter and response measured by the factory. Wherever possible this should be used as a reference for all subsequent tests.

Test Searchline Excel units using the kit of functional test filters as follows:

- (1) Ensure the area is gas free.
- (2) Connect the SHC-1 Handheld Interrogator (see section 3.7.5) to the unit to be tested.
- (3) Select **DISPLAY** from the **Calibration** menu.
- (4) Slide a suitable functional test filter (see table below) into the cowling at the front of the receiver. This table shows the typical responses that can be expected for these filters.

T

Receiver Gas Calibration	Low test Filter	Typical Response	High Test Filter	Typical Response
Methane	D	0.50 – 1.1 LEL.m	F	1.5 – 3.2 LEL.m
Ethane	C or D	0.60 – 1.3 LEL.m	F	1.5 – 2.7 LEL.m
Propane	B or C	0.85 – 1.1 LEL.m	F	2.6 – 3.2 LEL.m
Butane	B or C	0.85 – 1.1 LEL.m	F	2.6 – 3.2 LEL.m
Pentane	B or C	0.85 – 1.1 LEL.m	F	2.6 – 3.2 LEL.m
Ethylene	B or C	0.50 – 1.3 LEL.m	E	2.6 – 3.2 LEL.m
Propylene	B	1.00 – 2.0 LEL.m	E	1.2 – 3.2 LEL.m
Butadiene	B	1.00 – 2.0 LEL.m	E	1.2 – 3.2 LEL.m

- (5) If this is the first time that the unit has been tested with this particular test filter, record the gas reading that is produced. This reading should be used to verify correct operation in the future.
- (6) If this is not the first time that the unit has been tested with this particular filter, note the gas reading and compare it to the original value recorded for this unit and filter. If the reading is within ± 0.5 LEL.m of the original value, the unit is working correctly.
- (7) If the reading is Ok, proceed to step 13. If not Ok, the unit may need cleaning and/or re-zeroing.
- (8) To clean the unit, first remove the test filter from the cowling.
- (9) Use a damp, lint-free, cloth or lens wipe to clean the windows of the transmitter and the receiver.
- (10) Zero the unit using the SHC-1 in **CALIBRATE** mode.
- (11) Re-insert the test filter into the cowling in front of the receiver and verify that the test reading is now within ± 0.5 LEL.m of the reading originally obtained with this filter. If the gas reading is still not within the expected range, check the system alignment (see section 3.7 Alignment and Commissioning) and repeat the test in step 6.
- (12) When finished, remove the test filter and cancel **INHIBIT** by selecting **MAIN** in the menu.
- (13) Disconnect the SHC-1 Handheld Interrogator.
- (14) Store the readings in a safe place.

4.3 CALIBRATION CHECK USING THE GASSING CELL

The gassing cell is designed to allow easy calibration checking using a high concentration test gas as opposed to the standard plastic test filters. The integrated LEL.m reading of the gas concentration in the cell can be calculated using the following formula:

$$\text{Int(LeI.m)}_{xl} = L_{\text{cell}} * (\text{Conc}_{\text{gas}} / \text{LEL}_{\text{gas}})$$

4. MAINTENANCE

where:

$\text{Int}(\text{lel.m})_{x_i}$ = Integrated LEL.m reading output by Searchline Excel in LEL.m.

L_{cell} = Length of cell in metres.

Conc_{gas} = Gas concentration in %v/v.

LEL_{gas} = Lower Explosion Limit of the gas in %v/v.

The test gas must be the same as the test gas used during the factory calibration of the Searchline Excel unit and ideally the concentration should be between 2 and 5 LEL.m and never below 1 LEL.m.

Note: Where a different test gas is used, the typical value for cross-sensitivity is not sufficiently precise to enable valid calibration checks to be performed using the Gassing Cell, however, response tests can be easily performed with the plastic Test Filters as described in section 5.1.2.

WARNING

Take the necessary precaution to ensure safety when dealing with these high concentration gasses.

The gassing cell supplied by Honeywell Analytics (Part No: 2104B2326) is 0.15m long and the following table outlines the response expected when using this gassing cell:

Gas type	LEL of the gas	Concentration applied	Calculated response with 0.15m gas cell.	4-20mA output
Methane	5.0 %v/v	100 %v/v	3 LEL.m	13.6mA
Ethane	3.0 %v/v	50 %v/v	2.5 LEL.m	12mA
Propane	2.0 %v/v	50 %v/v	3.75 LEL.m	16mA
Butane	1.5 %v/v	50 %v/v	5 LEL.m	20mA

Gas type	LEL	Concentration applied	Calculated Response	4-20mA output
Ethylene	2.7%	54%	3 LELm	13.6mA
Propylene	2.0%	50%	3.75 LELm	16mA
Butadiene	2.1%	42%	3 LELm	13.6mA

WARNING

These gases are flammable and/or toxic.
Take appropriate precautions when handling.

4. MAINTENANCE

To get the best accuracy when using the gassing cell:

- (1) Connect the gassing cell to the Searchline Excel.
- (2) Zero Searchline Excel with the empty gassing cell.
- (3) Apply the test gas to the gassing cell and allow sufficient time to fully flush the cell without pressurising it and check that the Searchline Excel output stabilises.
- (4) Check the Searchline Excel output is as indicated in the above table $\pm 5\%$ fsd.
- (5) Remove the gassing cell.
- (6) Re-zero Searchline Excel.

Note: Pentane cannot be used with the gassing cell. At normal temperatures, this substance does not vapourise sufficiently to give a useful signal in the short path of the gassing cell.

4.4 DISPLAY GAS READING

This procedure displays details about the current gas/gas table. Carry out the following procedure:

- (1) Connect the SHC1 Handheld Interrogator to the gas detector.
See **Connecting the Interrogator to the Searchline Excel Gas Detector** in section 3.7.6.
- (2) Switch on the SHC1 Handheld Interrogator.
See **Powering Up** in section 3.7.6.
- (3) Select **DISPLAY** from the **Main** menu by pressing the ▲ (up) and ▼ (down) keys on the keypad to navigate through the menu options.
- (4) Press ↵ on the Interrogator keypad to display the **Display** menu.
- (5) Select **GAS READING** from the **Display** menu.
- (6) Press ↵ on the keypad.

A display similar to the following is now displayed.

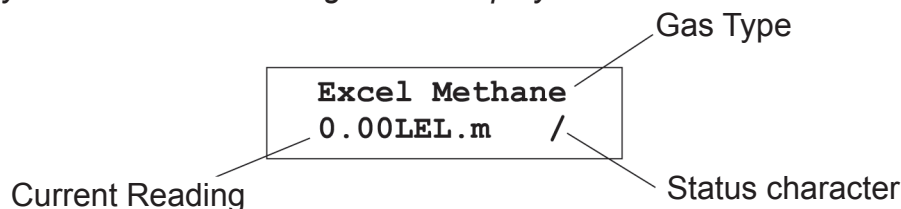

The first line of the display shows the name of the gas or its identifier in a special gas table.

The second line shows the gas reading and measurement units along with a gas detector

4. MAINTENANCE

status indicator.

The status character at the end of the second line indicates one of the following:

/ - Normal Operation

A spinning line shows the unit is in the fully active state.

| - Inhibit State

A stationary line shows the unit is in the Inhibited state.

w - Active Warning

F - Active Fault

B - Beam Blocked

- (7) Switch off the Interrogator (see section **3.7.7 Finishing Up**) and disconnect it from the gas detector.

4.5 ALIGNMENT TELESCOPE

To clean the telescope lens/mirror:

- (1) Moisten the surface of the lens/mirror by breathing on it.
- (2) Using a soft tissue or lens cloth, lightly wipe the lens/mirror dry with a minimum number of strokes.

The wiping material may be slightly dampened with a lens cleaning fluid as sold in any camera store.

4.6 OPERATIONAL MAINTENANCE (FM)

As required as a criterion for the FM Performance Approval, routine operational verification is recommended once within a three month period and is required once within a six month period using one of the following methods.

WARNING

The following procedure will indicate a gas reading. Ensure that any executive action has been inhibited prior to starting and completing the procedure.

- Following the procedure described in section **4.3**, test the unit's response to high %V/V gas in a gassing cell. Verify that the response is within the tolerance for stability and repeatability.

5. PROBLEM SOLVING

The majority of gas detector problems/faults can be diagnosed and corrected using the installation and alignment kit.

The alignment kit includes:

- **SHC1 Handheld Interrogator**
- **alignment telescope**
- **set of functional test filters**

An electrical multimeter is also useful when diagnosing electrical/wiring problems.

Refer to the troubleshooting tables in this chapter for a list of problems, possible causes and actions.

Caution: Searchline Excel does not contain any user serviceable parts. Do not open either the Transmitter or Receiver unit. The warranty of units which have been opened is invalidated.

NOTE: THE INFRARED BEAM IS INVISIBLE AND EYE SAFE.

RS485 Modbus signal errors may occur when Excel is connected via a DVC100(M) MK2 or DX100(M) Termination Unit and is interrogated/commanded from a network control centre. For troubleshooting these issues refer to the **DX100 Series Termination Units Technical Handbook**.

If, after following the recommendations in this section, the problem persists, please make available the following information before contacting Honeywell Analytics:

- **Installation Check Sheet**
See **Chapter 3**.
- **Any error message**
Displayed on the Handheld Interrogator screen.
- **Any error code**
Displayed on the Handheld Interrogator screen.

Fault/Problem	Causes	Remedies
Output is 0mA	Unit is in <i>FAULT</i> condition	Connect the SHC1 Interrogator to the unit and use its DIAGNOSTIC menu options to ascertain the reason for the FAULT report.
	Beam block	Check that beam path is clear from the Transmitter to the Receiver. Remove any obstruction if present.
	Transmitter or Receiver misaligned	<ol style="list-style-type: none"> 1) Connect the SHC1 Handheld Interrogator to the unit and check the signal levels. 2) If signal levels are low, use the telescope and Interrogator to optimise Receiver alignment. 3) If signal levels remain low after re-aligning Receiver, check the Transmitter alignment using telescope. 4) Re-zero the unit after alignment. See Appendix A.5.3.4.

5. PROBLEM SOLVING

Fault/Problem	Causes	Remedies
	Electrical installation problem	<ol style="list-style-type: none"> 1) Check that the +24V supply is reaching the unit. Voltage at the unit should be between +18V and +32V. 2) Check cables and connections to the unit, especially the 4-20mA loop connections. 3) Check that the unit has the correct type of 4-20mA output for use with the controller that it is connected to.
	Heavy contamination of optics	Check the Transmitter and Receiver windows for build up of contamination. Clean the windows if required. Re-zero unit.
	Very low visibility along beam path due to dense fog, blizzard or sand-storm conditions	<ol style="list-style-type: none"> 1) Check that the Transmitter can be seen from the Receiver. If Transmitter can be seen, even with some difficulty, low visibility is unlikely to be the problem. 2) If the Transmitter cannot be seen from the Receiver, very low visibility could be the problem. Wait until visibility improves and verify that the unit then returns to operational status.
Output is 2.5mA (BEAM BLOCK)	Beam path is blocked	Check that the beam path is clear from the Transmitter to Receiver. Remove any obstruction if present.
	Transmitter or Receiver misaligned	<ol style="list-style-type: none"> 1) Connect SHC1 Interrogator to unit and check signal levels. 2) If signal levels are low, use the telescope and SHC1 Interrogator to optimise Receiver alignment. 3) If signal levels remain low after re-aligning Receiver, check the Transmitter alignment using the telescope. 4) Re-zero the unit after alignment. See Appendix A.5.3.4.
Output is 3mA (LOW SIGNAL)	Heavy contamination of optics	Check the Transmitter and Receiver windows for build up of contamination. Clean windows if required. Re-zero the unit.
	Transmitter or Receiver misaligned	<ol style="list-style-type: none"> 1) Use the telescope and Interrogator to optimise Receiver alignment. 2) If signal levels remain low after re-aligning Receiver, check the Transmitter alignment using the telescope. 3) Re-zero the unit after alignment. See Appendix A.5.3.4.
Output is 2mA (INHIBIT)	Unit has been inhibited by the Interrogator	Release output from INHIBIT state using SHC1 Interrogator.
	Unit executing power-up routine	<ol style="list-style-type: none"> 1) Wait for 1 minute. When power-up routine is completed satisfactorily the unit's output should exit the INHIBIT state. 2) If unit remains in INHIBIT, check the +24V supply is reaching the unit. If the voltage is below +18V or is fluctuating above and below +18V, the unit may be being prevented from completing power-up. (This is an electrical installation problem.)

5. PROBLEM SOLVING

Fault/Problem	Causes	Remedies
Comms Error reported by Interrogator software	Wrong communication mode selected on the Interrogator	1) Select Change Mode option on the Interrogator. 2) Change the communication mode to Excel .
	Interrogator software version is incompatible with Excel software version	Version 1V00 Interrogator software to be Excels running 1V0 software. Version 2V0 Interrogator software can be used with Excels running 2V0 software or higher. Version 3V0 and 3V1 Interrogator software can be used with Excels running 3V0 software or higher. The latest version of Interrogator software is greater than 4V0 . This version works with 3V0 and higher Excels, Optima and Optima Plus. CSA/FM versions of the SHC-1 are programmed with version 4V1 of the interrogator software, which displays the units of measurement for the Cross-Duct version as %LEL/m.
	Incorrect communication connection	1) Check that Interrogator is correctly plugged into the IS socket on the DX100(M) or OELD junction box. 2) Check that the RS485 A and B wires from the Excel unit have been connected to the correct terminals inside the DX100(M) or OELD junction box.
	Excel unit is not powered up	Check that the +24V supply is reaching Excel unit correctly. The Supply voltage at unit should be between +18V and +32V.
	Interrogator battery low	Check the Interrogator battery and replace if low. See Appendix A. Section A.4.3.
Interrogator Installation Failed message when attempting initialisation	The installation has failed to meet the acceptable criteria of the Instrument Assisted Alignment (IAA) check	1) Check that the signal levels reaching the Receiver are greater than 0.7 and less than 2.0. 2) Check that the correct range has been entered for the installed path length. 3) Check that the alignment of the Receiver has been fully optimised. The received signals must be peaked up to the maximum achievable. Adjusting the alignment until the signals are just above the minimum signal threshold and then leaving it at that is poor practice and will not always result in an installation that passes the IAA check criteria. 4) Check the alignment of the Transmitter. 5) Check that there are no objects obscuring part or all of the beam path. 6) Check that the windows of both the Receiver and the Transmitter are clean. 7) Check that the structures that the Transmitter and Receiver are mounted on are stable and free from significant angular movement/vibration. 8) Check that there is no gas in the beam - which prevents successful zeroing. 9) Installation will fail in conditions of low visibility or fluctuating atmospheric transmission - which degrade signal quality. Do not attempt installation during conditions of heavy rain, snow or fog.

5. PROBLEM SOLVING

Fault/Problem	Causes	Remedies
No signal or very low signal at Receiver	Receiver misaligned	Re-align the Receiver, first using the telescope and then using the Interrogator.
	Transmitter misaligned	Re-align the Transmitter using the telescope.
	The beam path has become obscured	Check that the beam path is clear from Transmitter to Receiver. Remove any obstruction if present.
	No output from Transmitter	1) Check that the Transmitter is flashing. Alternatively, listen for a distinct ticking sound when the lamp flashes. <i>Note: The infrared beam is invisible and eye safe.</i> 2) If the Transmitter is not flashing, check that the +24V supply is reaching the Transmitter correctly.
Unit does not respond exactly as expected to	Plastic test filters are only an approximate simulation of gas	Searchline Excel units are calibrated on real gas. This results in a variation of the response test filters of different Excel units to plastic test filters. See section 5.1.2. 1) Check that the response to the test filters is within the limits stated in this handbook. See section 5.1.2. 2) Check that the value being used for response testing corresponds correctly to the target gas that the unit has been calibrated for.
	Receiver misaligned	1) Use the telescope and Interrogator to optimise Receiver alignment. 2) Re-zero unit.
	Contamination of windows	1) Check the Transmitter and Receiver windows for build up of contamination. Clean windows if required. See Chapter 5 . 2) Re-zero unit.
	Drift of unit's zero position	1) Verify that there is no gas in the beam path. 2) Re-zero the unit.
Unit appears to be reporting a negative gas reading on the 4-20mA	Misinterpretation of INHIBIT , BEAM-BLOCK or LOW SIGNAL currents that are output on the 4-20mA	Searchline Excel does not report negative gas readings on the 4-20mA. 1) Configure controller/PLC to interpret and present currents below 4mA correctly, or , 2) Familiarise operators with the interpretation of sub-4mA output currents from Excel as follows: FAULT 0mA INHIBIT 2mA BEAM-BLOCK 2.5mA* LOW SIGNAL 3mA* or , 3) Reconfigure the INHIBIT , BEAM-BLOCK and LOW SIGNAL currents output by the Excel unit.

5. PROBLEM SOLVING

Fault/Problem	Causes	Remedies
Diagnostics report Neg Gas Reading	Receiver misaligned	1) Re-align the Receiver, first using the telescope and then using the Interrogator. 2) Re-zero the unit.
	Contamination of windows	1) Check the Transmitter and Receiver windows for build up of contamination. Clean windows if required. See Chapter 5 . 2) Re-zero the unit.
	Negative drift of unit's zero position	Re-zero the unit.
Diagnostics report Baseline Drift	Receiver misaligned	1) Re-align the Receiver, first using the telescope and then using the Interrogator. 2) Re-zero the unit.
	Contamination of windows	1) Check the Transmitter and Receiver windows for build up of contamination. Clean windows if required. 2) Re-zero the unit.
	Drift of unit's baseline	Re-zero the unit
Diagnostics report Bad Temperature	Unit has been operated at a temperature outside its specified and certified range	1) When Ex certified equipment is operated outside its certified range, its type approval certification is invalidated along with its warranty. Such equipment should be removed from service in potentially explosive atmospheres. 2) Investigate the cause of the excessive temperature excursion and take steps to prevent recurrence. (e.g. fit sunshade or heat-shield, or relocate detector, etc.)
Diagnostics report Supply Fault	Incorrect supply voltage reaching unit	1) Check that the +24V supply voltage is reaching the unit (it should be between +18V and +32V). 2) Identify the cause of incorrect supply voltage reaching the unit and rectify.
Diagnostics report DSP Fault	Fault on the unit's digital PCB	If this fault is displayed when the unit is interrogated, it cannot be remedied in the field.
Diagnostics report NV-RAM Fault	A fault has been detected in the NV-RAM	If this fault is displayed when the unit is interrogated, it cannot be remedied in the field.
Diagnostics report RTC Fault	The time and date record being stored by the Real Time Clock (RTC) has been lost	1) Re-enter the time and date using the Interrogator. 2) Cycle the power applied to the unit. 3) Verify that the time and date record was maintained after cycling the power.
Diagnostics report Volt Ref Fault	Voltage reference fault detected	If this fault is displayed when the unit is interrogated, it cannot be remedied in the field.

6. SPECIFICATIONS

6.1 SYSTEM

OPEN-PATH						
Available Gases	Methane ^{1,2} , Ethane ¹ , Propane ^{1,2} , Butane ¹ , Pentane, Ethylene, Propylene, Butadiene 1: FM Performance Approved 2: DNV approved					
Range	0 - 5 LELm					
Recommended Alarm Setting	Low 1 LELm High 3 LELm					
Minimum Alarm Setting	0.5LELm					
Path Length	Short Range: 5 - 40m (15 - 130ft)		Medium Range: 40 - 120m (130 - 390ft)		Long Range: 120 - 200m (390 - 650ft)	
Speed of Response	T90 less than 3 seconds					
Output Signal	4 – 20 mA Normal operation (linearised 0 – 5 LELm)	0 mA Fault	2 mA Inhibit	2.5 mA Beam block*	3 mA Low signal	21 mA Overrange
*Searchline Excel will indicate Beam Block after 30 s without signal. After a further 120 s it will indicate Fault. These values are programmable; please refer to Appendix A for details. To comply with FM performance approval, the maximum value for Time to Block is 200 s.						
<i>Note: For safety reasons, if Searchline Excel loses signal while measuring a gas reading above its internal Alarm threshold (default 1 LELm) it will not indicate beam block. Instead it will hold the previous gas reading until it is again able to measure the current gas concentration. Operator intervention may be required to remove a blockage from the beam.</i>						
Operating and Storage Temperature	40°C to +65°C (-40°F to +150°F). DNVGL-CG-0339 Location Class B					
Humidity	0 – 99%RH Non-condensing . DNVGL-CG-0339 Location Class B					
Pressure	91.5kPa – 105.5kPa (915 – 1055mBar, non-compensated)					
Repeatability	±0.4LELm					
Temperature Drift (-40°C to+65°C)	±0.2LEL.m @ zero ±0.5LEL.m @3LEL.m					
Warm-up Time	Less than 5 minutes (operational), Less than 1 hour (fully stabilised)					
Power Supply	18 to 32Vdc					
Power Consumption	* Turbo heating activated (below 0°C)					
Transmitter Receiver	Short Range: 3.5/5* W max 8W maximum		Medium / Long Range: 10/13* W max.			
Inrush Current						
Transmitter	Short Range: < 0.3 A		Medium/Long Range: < 0.9 A			
Receiver	< 0.6 A					
Enclosure Material	316 Stainless Steel					
Weight						
Transmitter	Short Range: 3.5kg		Medium / Long Range: 7.0kg			
Receiver	3.5kg					
Vibration	2 – 60Hz, maximum peak to peak amplitude 1mm FM 10 - 30 Hz, 1 mm; 31 - 150 Hz, 2g. DNVGL-CG-0339 location classes A and C when used with Maritime Bracket and associated hardware (see Appendix 4).					
Divergence/ Misalignment Tolerance	Short Range: ±0.5° (~±35cm at 40m)		Medium Range: ±0.5° (~±105cm at 120m)		Long Range: ±0.5° (~±175cm at 200m)	
IP rating	IP66/67					
EMC / EMI	EN 50270 / Immune to FM Modulated Portable Radio Transmitters (5 W at 1 m, 150-179 MHz and 450-470 MHz) . DNVGL-CG-0339 Location Classes A and B.					

6. SPECIFICATIONS

6.2 DETECTABLE GASES

The Searchline Excel Open-Path gas detector (short, medium and long range) will detect the following hydrocarbon gases, individually or in a mixture, in the range 0-5 LEL.m:

Gas		LEL (% v/v)		FM Performance Approved	DNV Approved
		ATEX / IECEx Units	UL / CSA / FM Units		
Methane	CH ₄	4.4	5.0	✓	✓
Ethane	C ₂ H ₆	2.5	3.0	✓	
Propane	C ₃ H ₈	1.7	2.0	✓	✓
Butane	C ₄ H ₁₀	1.4	1.5	✓	
Pentane	C ₅ H ₁₂	1.4	1.4		
Ethylene	C ₂ H ₄	2.3	2.7		
Propylene	C ₃ H ₆	2.0	2.0		
Butadiene	C ₄ H ₆	1.4	1.4		

Searchline Excel Raw Gas Response Before Linearity Correction

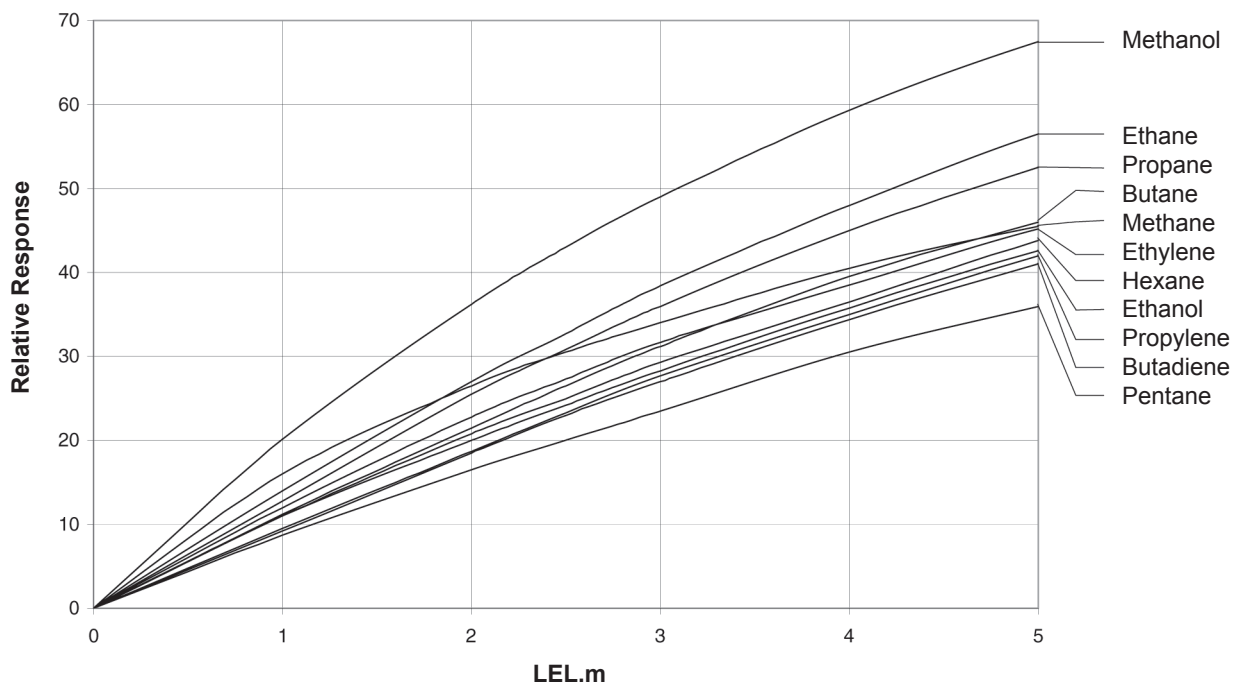

Cross-sensitivity to other gases

7. CERTIFICATION

7.1 GENERAL

The Searchline Excel system has the following ATEX, IECEx, UL, FM and CSA approvals for worldwide acceptance:

ATEX & IECEx

Transmitters: Ex II 2G, Ex d op is IIC Gb T5 (T_{amb} -40 to +65°C)
T6 (T_{amb} -40 to +40°C)

Receivers: Ex II 2G, Ex d IIC Gb T5 (T_{amb} -40 to +65°C)
T6 (T_{amb} -40 to +40°C)

Certificate Numbers:

Open Path Short Range Transmitter, Short/Mid and Long Receivers: BAS98ATEX2165X.

Open Path Long Range/Mid Range Transmitters: BAS98ATEX2299X.

Open Path Short Range Transmitter, Short/Mid and Long Receivers: IECEx BAS 09.0100X

Open Path Long Range/Mid Range Transmitters: IECEx BAS 09.0101X

UL

Class I Groups B, C, D

Class I Zone 1 AEx d IIB + Hydrogen (Amb -40°C to +65°C)

File No. E91044

CSA

Class I Div 1 groups B, C, D, T5 and

Exd IIC T5 (Amb -40 to +65°C)

File No. LR 48148-38

FM

Class I Div 1 groups B, C, D & T5

(T_{amb} -40 to +65°C)

Performance approved ANSI/ISA-12.13.04/FM6325 for Methane, Ethane, Propane and Butane

DNV

Temperature D; Vibration A C; Humidity B; EMC B; Enclosure IP66/67

Certificate Number: TAA000014V

The Searchline Excel system has been designed, built and tested to meet the latest European standards for Radio Frequency Immunity (RFI).

It has been tested and approved to the following European regulations: EN50270.

Searchline Excel is Immune to FM Modulated Portable Radio Transmitters (5 W at 1 m, 150-179 MHz and 450-470 MHz).

7. CERTIFICATION

7.2 ATEX & IECEX

7.2.1 Transmitter Details

Open-Path

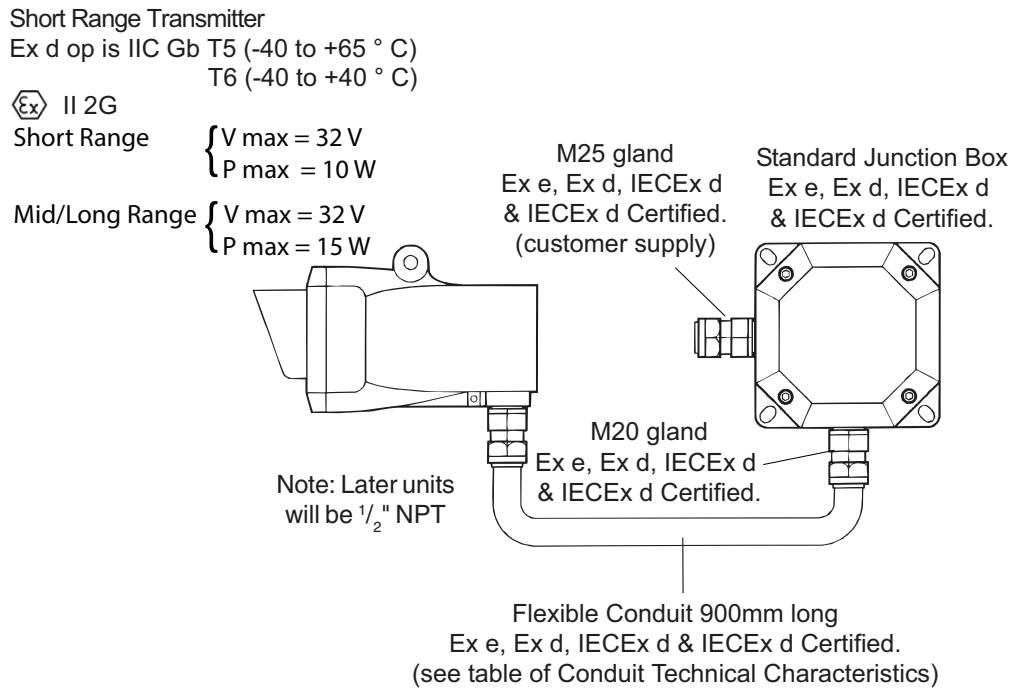

7.2.2 Receiver Details (for all Receivers)

Open-Path

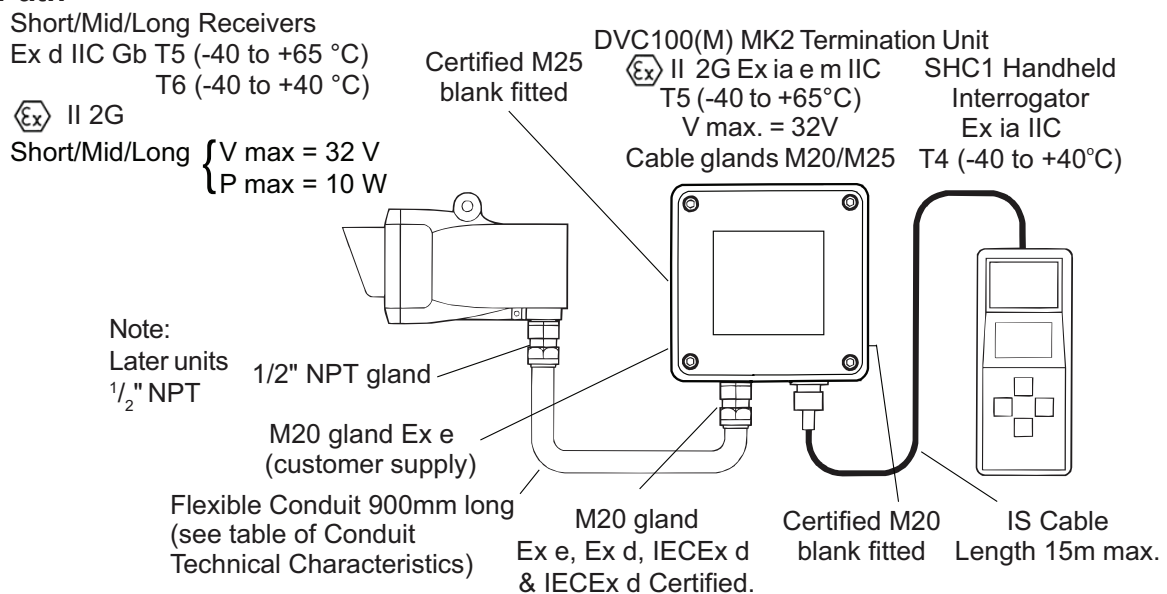

7. CERTIFICATION

7.2.3 Conduit Technical Characteristics

Ingress Protection	IP66 and 67.
Temperature Rating	-40 to +105°C.
Construction	A helically wound galvanised steel core with cotton packing and enhanced oil resistant PVC covering. Covering material displays good resistance to dilute acids, alkalis and hydrocarbon products.
Colour	Grey
Electrical Flash Voltage	More than 24kV.
Insulation Resistance	More than 100M ohms.
Connector Pull off Classification	FRG04: Heavy.
Conductor Crush Classification	FRG04: Heavy.
Flame Propagation	Flame dies in less than 30 seconds after ignition source is removed.
Approvals	Bureau Veritas.

7.2.4 Certification Labels for all Receivers

Identification number of ATEX notified body (points to CE mark)

CE mark (points to CE mark)

Conforms to all applicable European directives (points to CE mark)

Explosion protection mark and equipment group and category (points to Ex d IIC Gb T6)

Serial number (points to the empty box for the serial number)

Certification numbers (points to the empty box for certification numbers)

Certification code as IEC / EN60079-0: IEC / EN60079-1: and IEC / EN 60079 - 28 (points to the empty box for certification code)

Product name and part number (points to PART No.2104B20XX Rx SHORT)

Indicates type of receiver (e.g. Rx short shown here) (points to Rx SHORT)

Certified ambient temperature (points to Ta -40 to +40°C)

Modification status (points to Mod. box)

Warning (points to the warning text)

Label Content:
Honeywell
 POOLE UK
 MADE IN UK
SEARCHLINE
 e x c e l
 PART No.2104B20XX Rx SHORT
 BAS 98ATEX2165X
 IECEx BAS 09.0100X
 Ex d IIC Gb T6 (Ta -40 to +40°C)
 II 2 G T5 (Ta -40 to +65°C)
 Vmax=32Vdc Pmax=10W
 [] Mod. [] [] [] []
 WARNING: DO NOT OPEN WHEN AN EXPLOSIVE GAS ATMOSPHERE IS PRESENT. THIS APPARATUS MUST BE EARTHED. READ & UNDERSTAND INSTRUCTION MANUAL.

7. CERTIFICATION

Certification Label - Short Range Transmitter

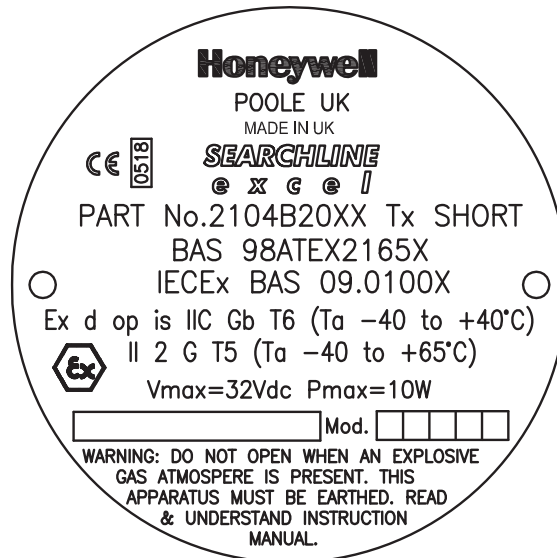

Certification Label - Mid and Long Range Transmitter

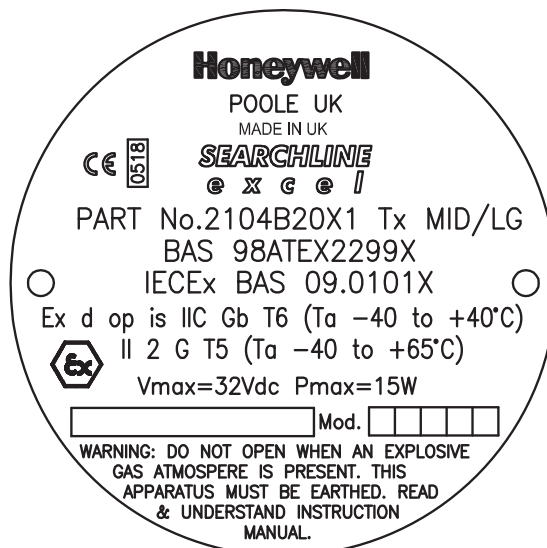

7. CERTIFICATION

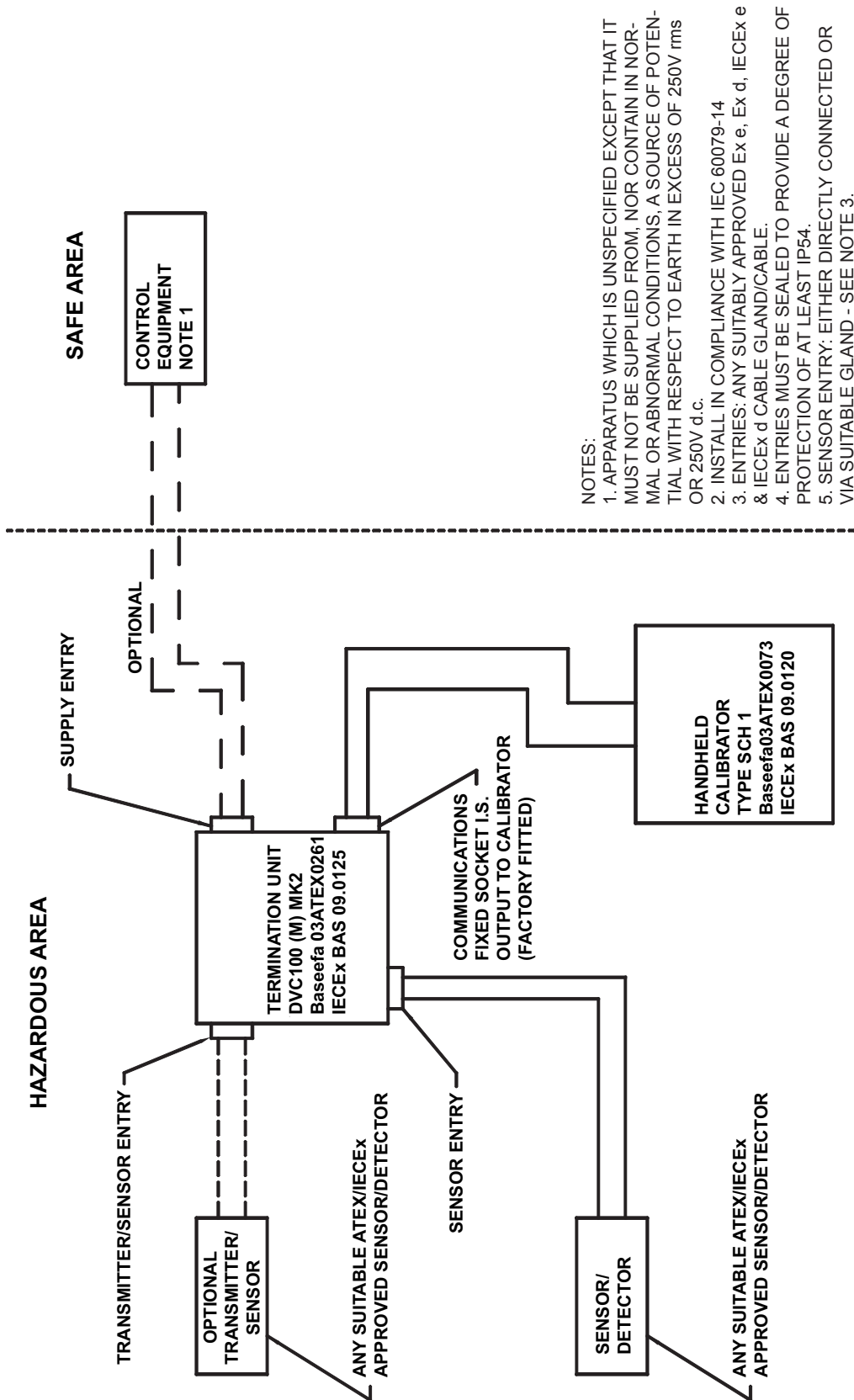

7. CERTIFICATION

7.2.5 System Diagram

NOTES:--

1. THE ELECTRICAL CIRCUIT IN THE HAZARDOUS AREA MUST BE CAPABLE OF WITHSTANDING AN a.c. TEST VOLTAGE OF 500V TO EARTH OR FRAME OF THE EQUIPMENT FOR A PERIOD OF 1-MINUTE WITHOUT BREAKDOWN.
2. THE INSTALLATION MUST COMPLY WITH NATIONAL REQUIREMENTS FOR INTRINSIC SAFETY Ex i (e.g. TO EN 60079-14, IEC 60079-14).
3. WIRING FROM THE HANDHELD CALIBRATOR TO THE TERMINATION UNIT IS NOT TO EXCEED 15 METRES MAX.
4. SUPPLY ENTRY: ANY SUITABLY APPROVED Ex e, Ex d, IECEx e AND IECEx d GLAND & Ex e CABLE 50V d.c. MAX. 5.0 AMPS d.c. MAX. THE INSTALLATION MUST COMPLY WITH NATIONAL REQUIREMENTS FOR INCREASED SAFETY Ex e. (e.g. TO EN 60079-17, IEC 60079-17).
5. THE SENSOR ENTRY MUST BE SEALED TO PROVIDE A DEGREE OF PROTECTION OF AT LEAST IP54.
6. APPARATUS WHICH IS UNSPECIFIED EXCEPT THAT IT MUST NOT BE SUPPLIED FROM, NOR CONTAIN IN NORMAL OR ABNORMAL CONDITIONS, A SOURCE OF POTENTIAL WITH RESPECT TO EARTH IN EXCESS OF 250V r.m.s. OR 250V d.c.
7. THE SENSOR FITTED MUST BE CERTIFIED BY ANY ATEX/IECEx APPROVED BODY AS EITHER Ex d IIC OR Ex e II & MUST MAINTAIN A DEGREE OF PROTECTION OF AT LEAST IP54 TO THE INSIDE OF THE TERMINATION UNIT & BE CAPABLE OF WITHSTANDING THE 7J IMPACT REQUIREMENT FOR Ex e & BE SUITABLE FOR DIRECT CONNECTION TO AN M20,M25 OR M27 GLAND ENTRY.

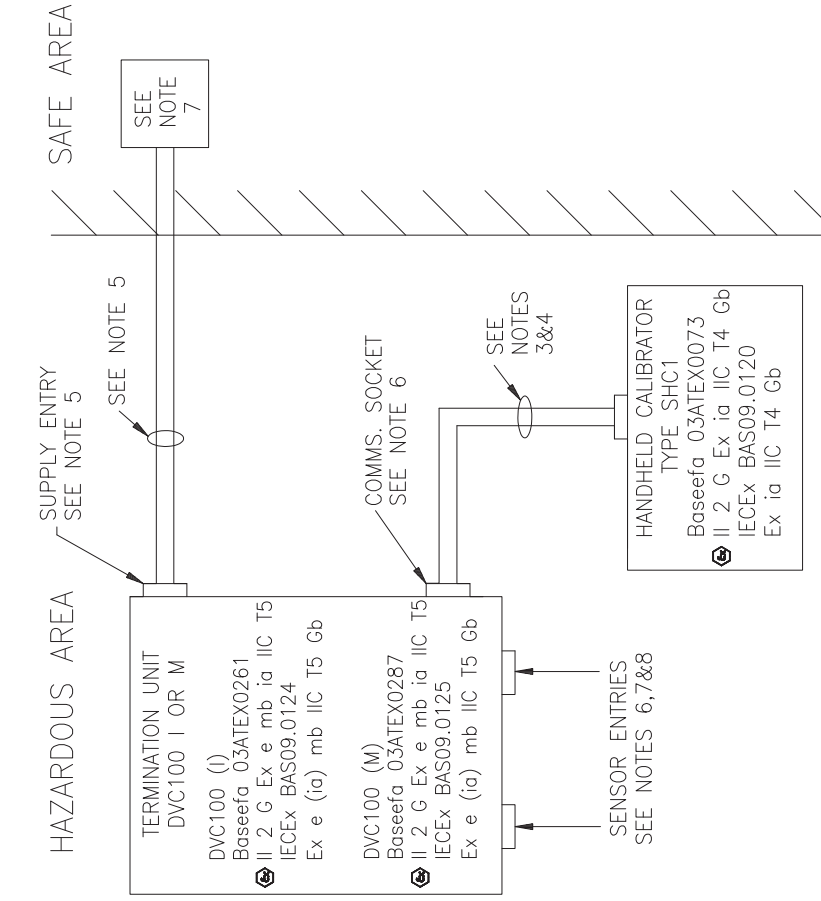

THIS ITEM FORMS PART OF A CERTIFIED PRODUCT. NO MODIFICATION PERMITTED WITHOUT REFERENCE TO CERTIFYING AUTHORITY	
DR'N	RCF
SCALE	22.7/10/09
TITLE	SEARCHLINE EXCEL
ISSUE	CERT DRG Rx
1	

FINISH	MATERIAL	SCALE	
		DR'N	RCF
ALL DIMENSIONS IN MILLIMETRES UNLESS OTHERWISE STATED AND APPLY AFTER PLATING	THIS DRAWING IS TO BS 8888	TITLE	
		SEARCHLINE EXCEL	
TOLERANCES TO BE AS SPECIFIED BELOW UNLESS OTHERWISE STATED.	DIMS.	ISSUE	
		2 DP ± 0.1 mm	1
THIS DRAWING IS TO BS 8888	NONE ± 0.4 mm	SEARCHLINE EXCEL	
		CERT DRG Rx	
THIS DRAWING IS CONFIDENTIAL. IT IS THE PROPERTY OF HONEYWELL ANALYTICS LTD AND MUST NOT BE	ANG111AD ± 1/2°	SEARCHLINE EXCEL	
		CERT DRG Rx	

7. CERTIFICATION

7.2.6 ATEX Special Conditions of Safe Use

7.2.6.1 Receiver and Short Range Transmitter

The integral supply cables must be mechanically protected and terminated in a suitable terminal or junction facility.

The cover fixing screws shall be grade 12.9 minimum.

7.2.6.2 Mid and Long Range Transmitters

The integral supply cables must be mechanically protected and terminated in a suitable terminal or junction facility.

7. CERTIFICATION

7.3 UL

7.3.1 Transmitters

Open-Path

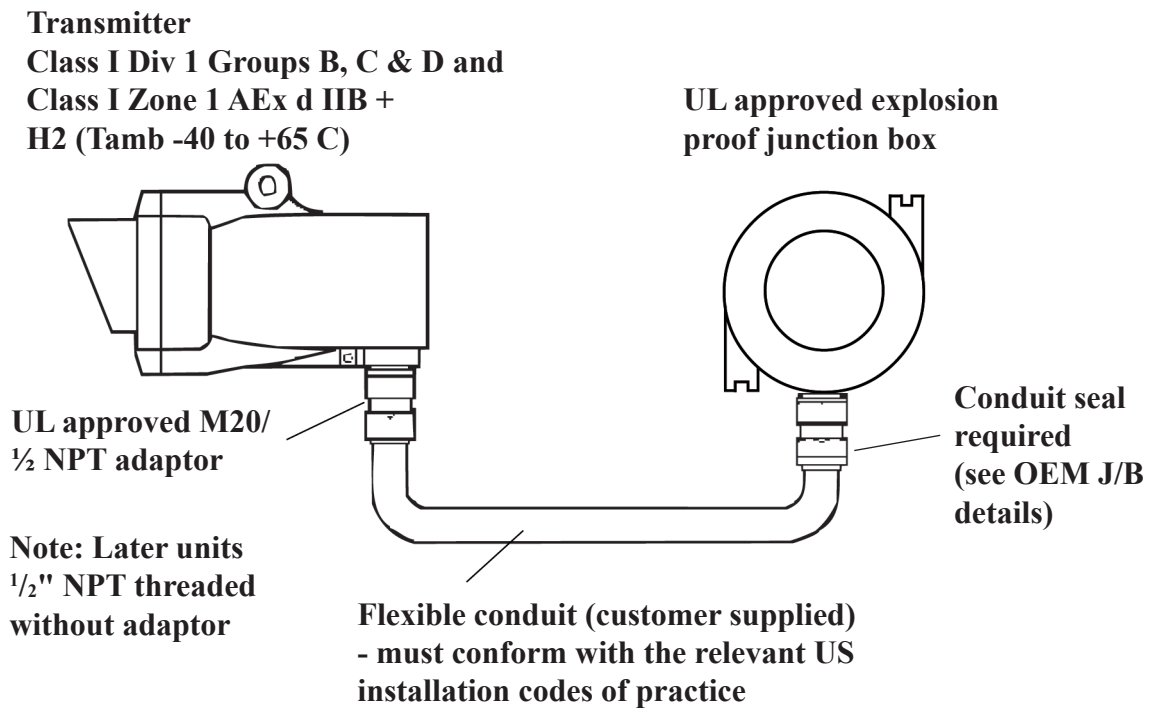

7.3.2 Receivers

Open-Path

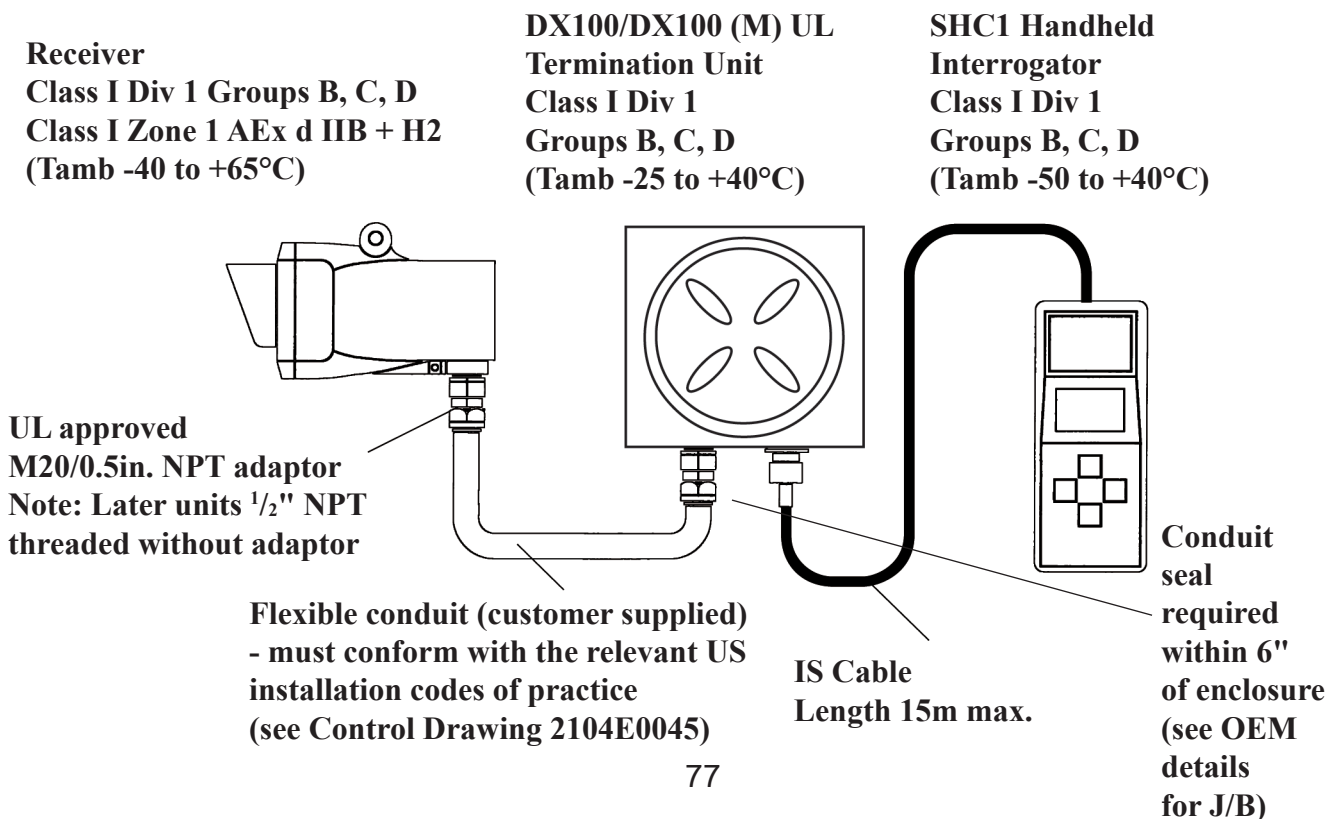

7. CERTIFICATION

7.3.3 System Diagram

With DX100 Termination Unit

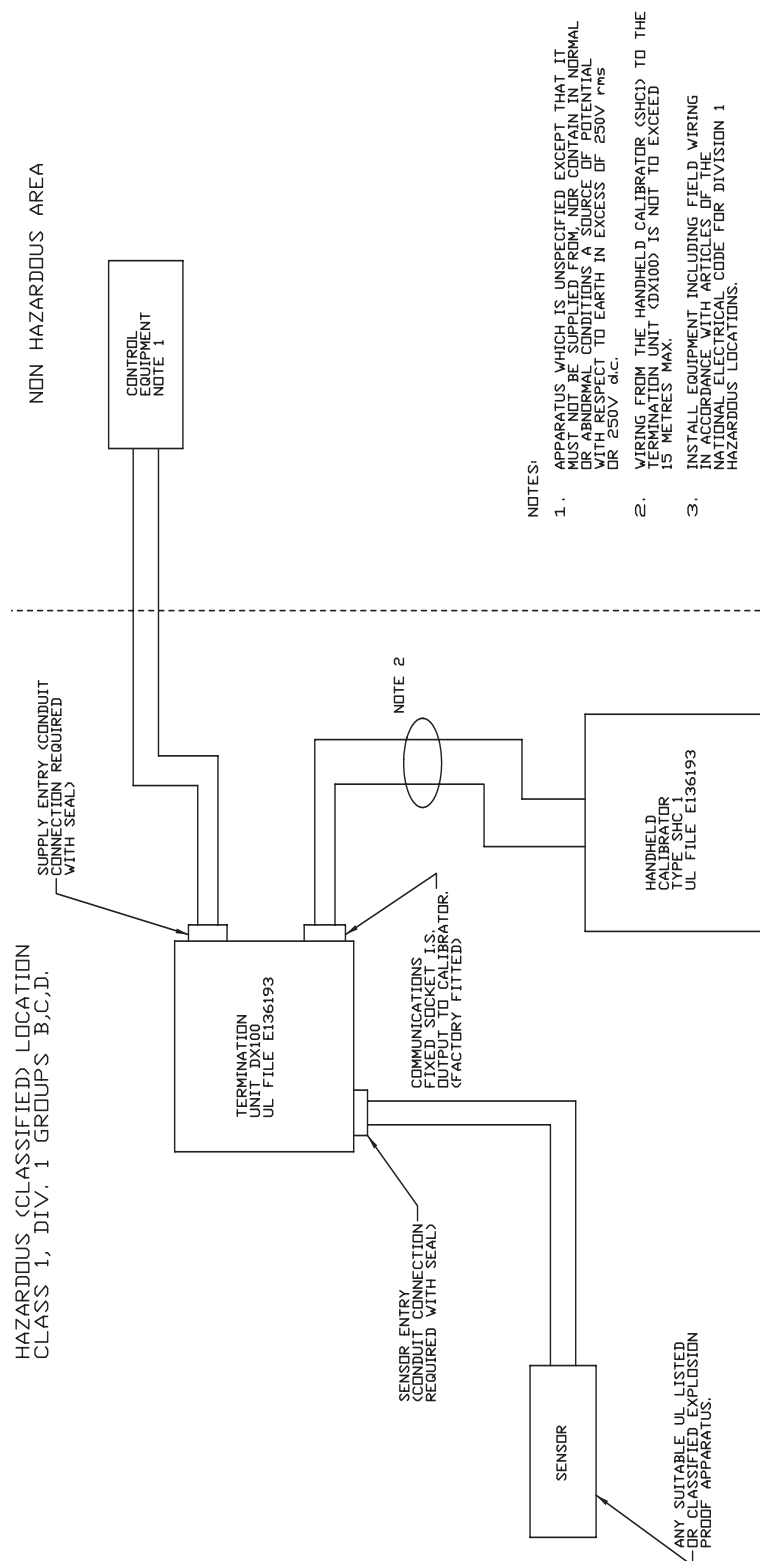

7. CERTIFICATION

With DX100 (M) Termination Unit

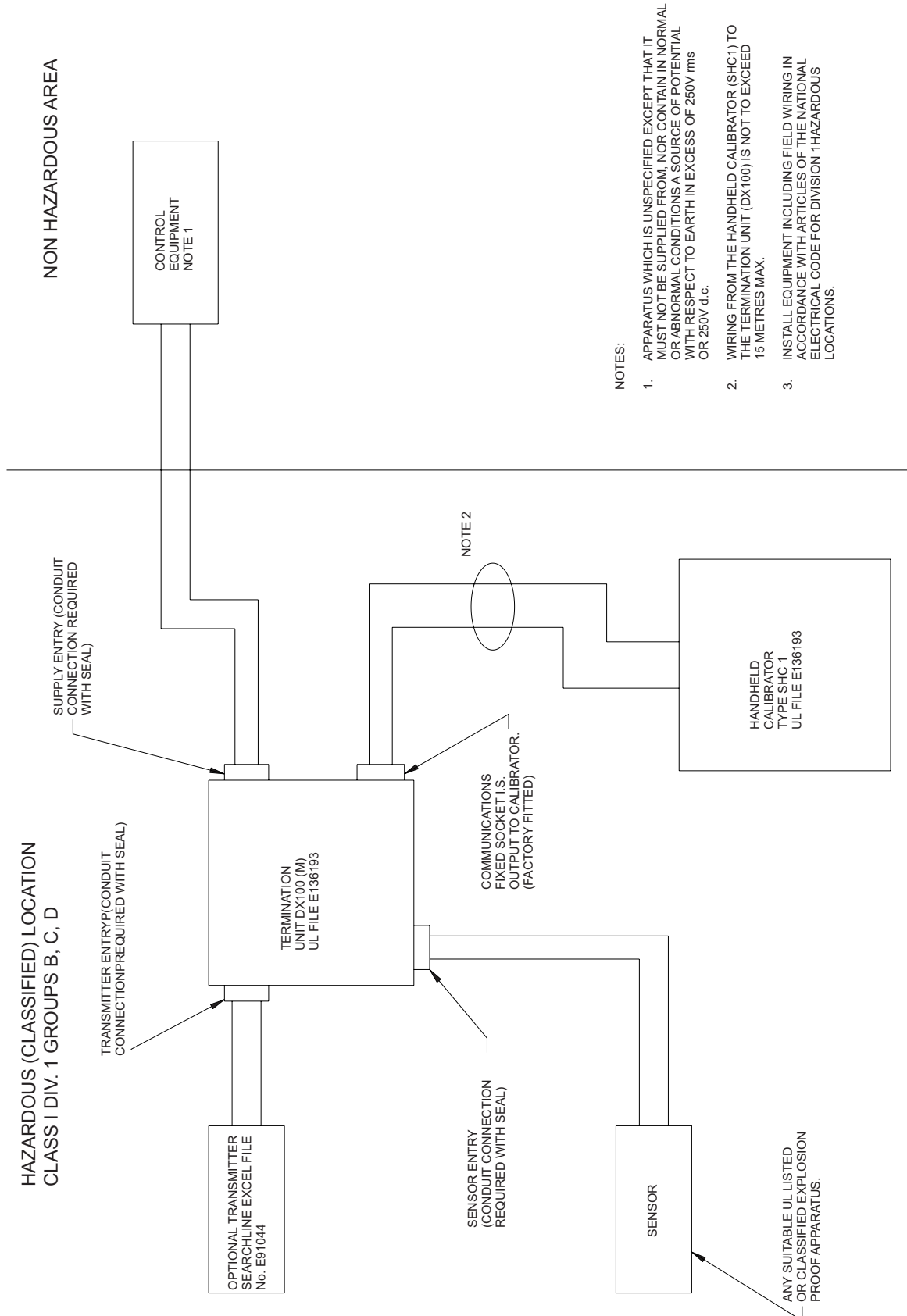

- NOTES:
1. APPARATUS WHICH IS UNSPECIFIED EXCEPT THAT IT MUST NOT BE SUPPLIED FROM, NOR CONTAIN IN NORMAL OR ABNORMAL CONDITIONS A SOURCE OF POTENTIAL WITH RESPECT TO EARTH IN EXCESS OF 250V rms OR 250V d.c.
 2. WIRING FROM THE HANDHELD CALIBRATOR (SHC1) TO THE TERMINATION UNIT (DX100) IS NOT TO EXCEED 15 METRES MAX.
 3. INSTALL EQUIPMENT INCLUDING FIELD WIRING IN ACCORDANCE WITH ARTICLES OF THE NATIONAL ELECTRICAL CODE FOR DIVISION 1 HAZARDOUS LOCATIONS.

7. CERTIFICATION

7.4 CSA/FM

FM Approval

Complies with ANSI/ISA-12.13.04/FM6325 for Methane, Ethane, Propane and Butane (Short Range, Medium Range and Long Range Open Path Systems)

7.4.1 Transmitters

CSA Transmitter:

Class I Div 1 Groups B, C & D T5

and Exd IIC T5 (Tamb -40 to +65°C) FM Transmitter: CSA/FM approved

Class I Div 1, Groups B, C & D (-40 to +65°C)

explosion proof junction box

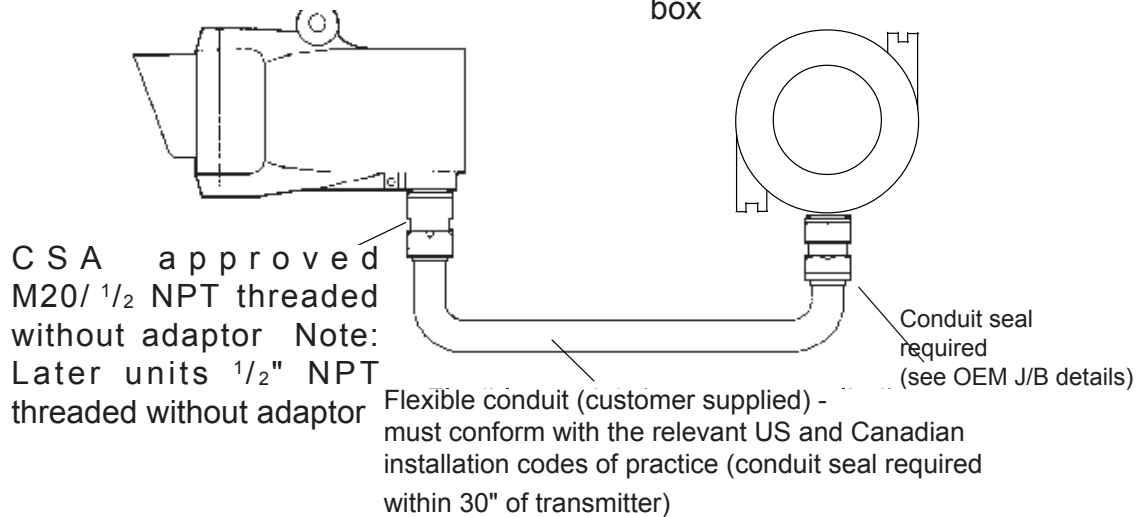

7.4.2 Receivers

CSA Receiver:

Class I Div 1 Groups B, C, D, T5 & Exd IIC T5 (Tamb -40 to +65°C)

DX100/DX100(M) CSA/FM Termination Unit Class I Div 1 Groups B, C, D (Tamb -55 to +40°C)

SHC1 Handheld Interrogator CSA/FM Class I Div 1 Groups B, C, D (Tamb -40 to +65°C)

FM Receiver:

Class I Div 1 Groups B, C & D

(-40 to +65°C)

CSA approved

M20/0.5in. NPT adaptor

Note: Later units 1/2" NPT threaded without adaptor

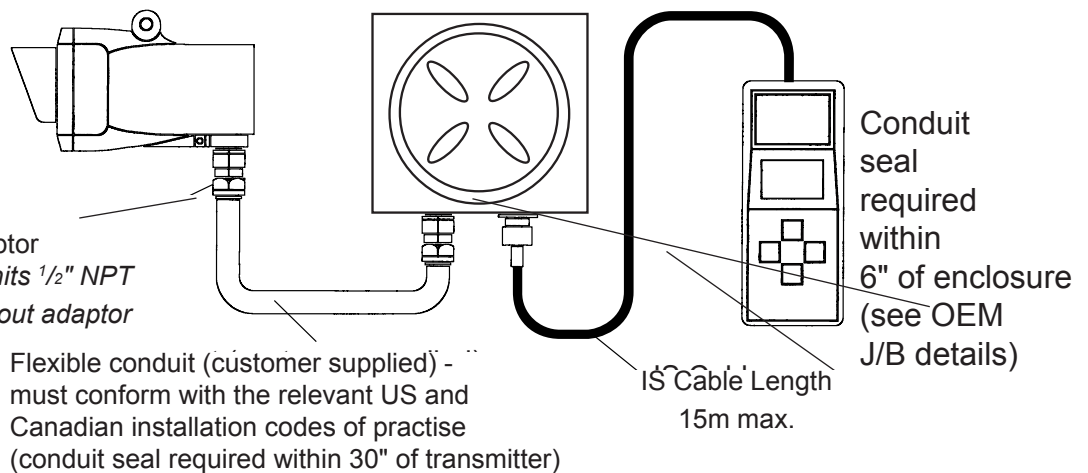

7. CERTIFICATION

CSA Receiver:
Class I Div 1 Groups B, C, D
T5 Ex d IIC T5
(Tamb -40 to +65°C)

DX100/DX100(M) CSA/FM
Termination Unit Class I Div 1
Groups B, C, D (Tamb -55 to +40°C)

SHC1 Handheld
Interrogator CSA/FM
Class I Div 1
Groups B, C, D
(Tamb -55 to +40°C)

FM Receiver:
Class I Div 1
Groups
B, C & D
(-40 to +65°C)

CSA approved
M20/0.5in. NPT adaptor
Note: Later
units 1/2" NPT
threaded without adaptor

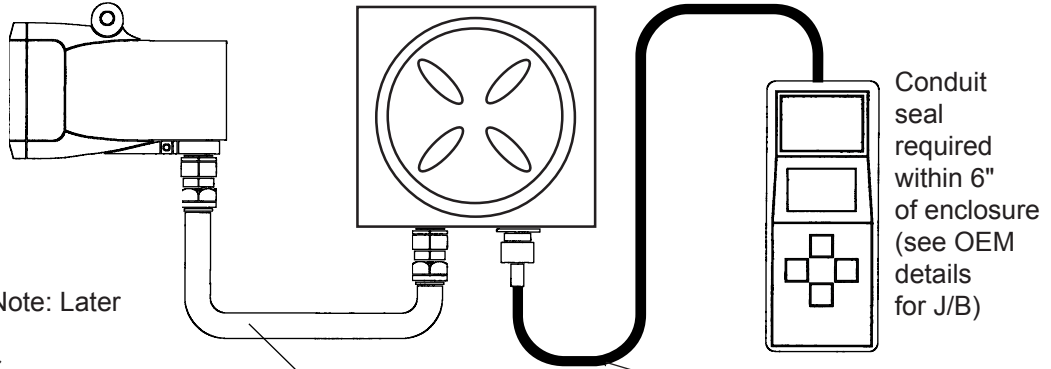

Conduit
seal
required
within 6"
of enclosure
(see OEM
details
for J/B)

Solid conduit (customer supplied) -
must conform with the relevant US and
Canadian installation codes of practice
(conduit seal required within 30" of transmitter)

IS Cable
Length
15m max.

7. CERTIFICATION

CSA/FM Certification Label

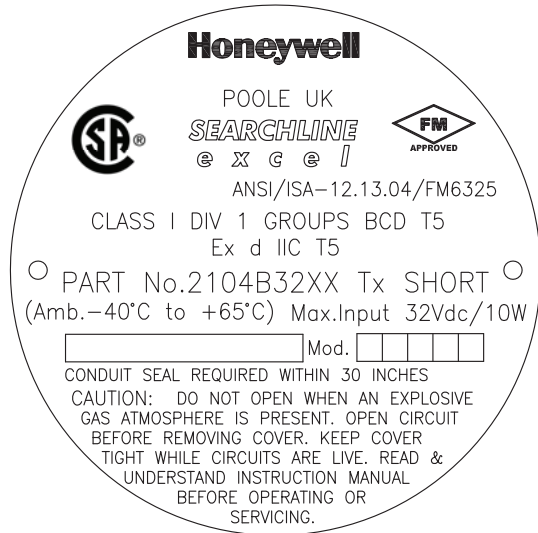

Short Range Transmitter

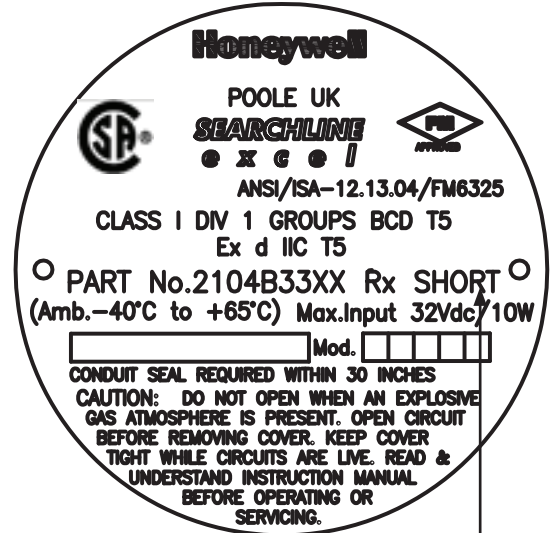

Receiver

Alternative 'MID' or 'LONG'
for other versions

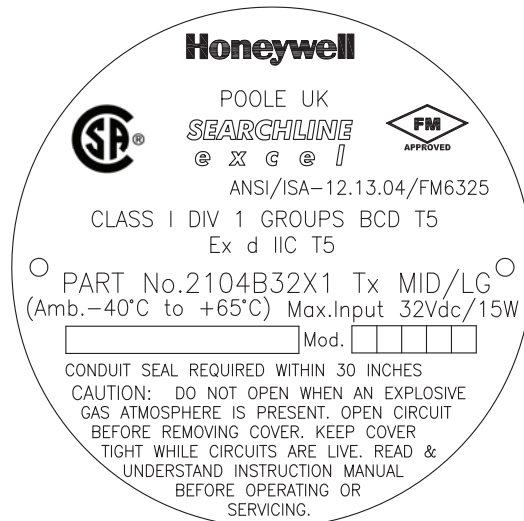

**Medium/Long Range
Transmitter**

7. CERTIFICATION

With DX100 (M) Termination Unit

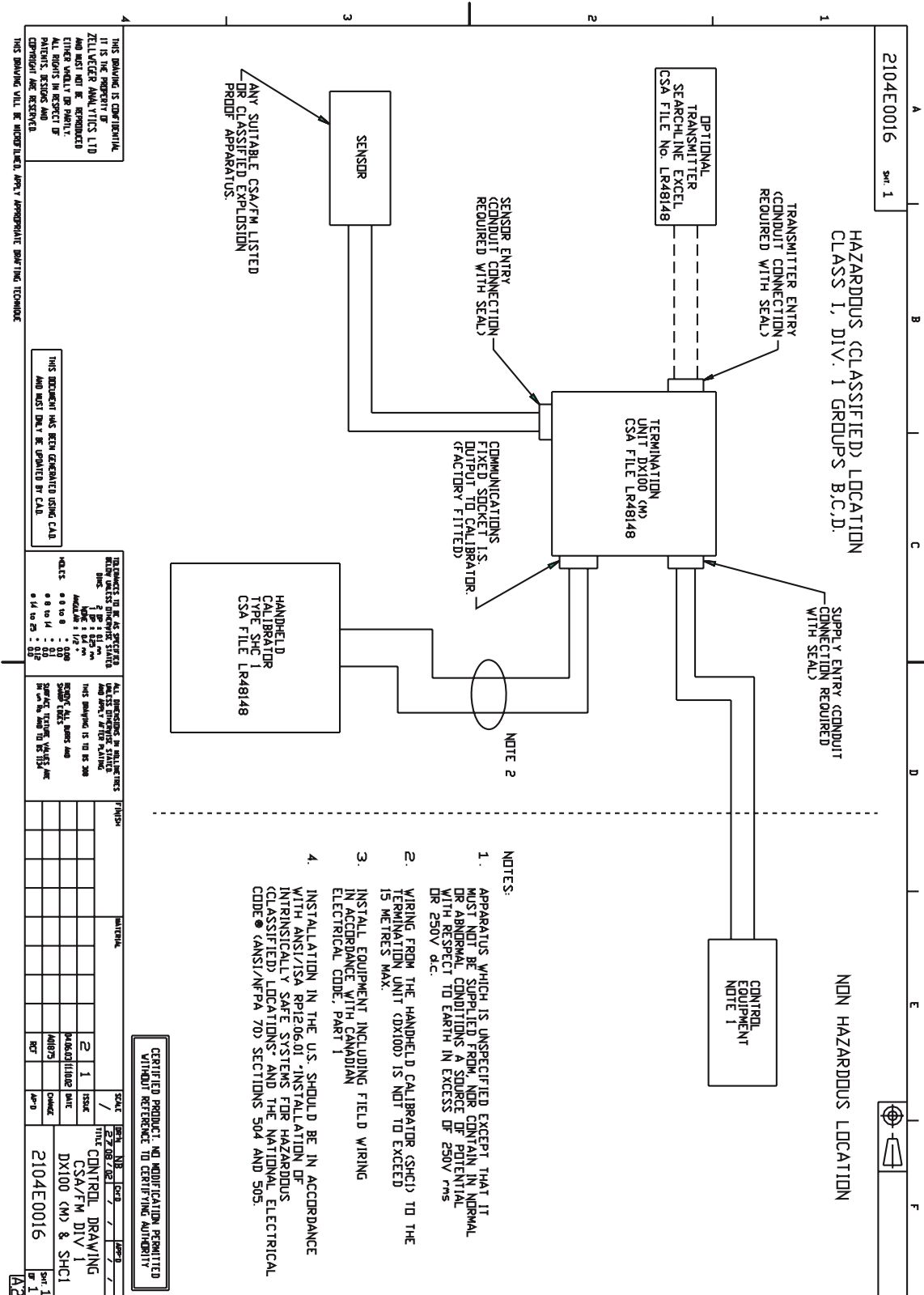

7. CERTIFICATION

7.5 ROHS - RESTRICTION OF HAZARDOUS SUBSTANCES

7.5.1 China RoHS

部件名称	有害物质					
	铅 (Pb)	汞 (Hg)	镉 (Cd)	六价铬 (Cr(VI))	多溴联苯 (PBB)	多溴二苯醚 (PBDE)
PCB 板	X	0	0	0	0	0

本表格中未列出的所有部件和配件包含的有害物质都没有超过 GB/T 26572 所要求的限制。

本表格依据 SJ/T 11364 的规定编制

○ : 表示该有害物质在该部件所有均质材料中的含量均在 GB/T26752 规定的限量要求以下。

× : 表示该有害物质至少在该部件的某一均质材料中的含量超出 GB/T26572 规定的限量要求。

APPENDIX A - HANDHELD INTERROGATOR

A.1 INTRODUCTION

This appendix provides reference information about the SHC1 Handheld Interrogator.

The interrogator provides the user end of a two-way communication link between the Excel system and the operator.

It features facilities which let the operator configure, align, functionally test and diagnose faults in the system.

The appendix gives:

- **an overview of the interrogator features**
- **information about how to connect the interrogator to the Excel systems**
- **basic user tasks, including switching on/off and changing the battery**
- **a detailed description of the menus which the interrogator provides**
- **problem solving information if trouble occurs when using the interrogator**

Details of how to use the interrogator for different tasks with the system are given **Chapter 3** and **Chapter 4** of this handbook.

A.2 OVERVIEW

The interrogator consists of an LCD screen and four keypad buttons. It links to the Excel Receiver unit via an IS connector on the end of a flexible cable connected to the associated junction box.

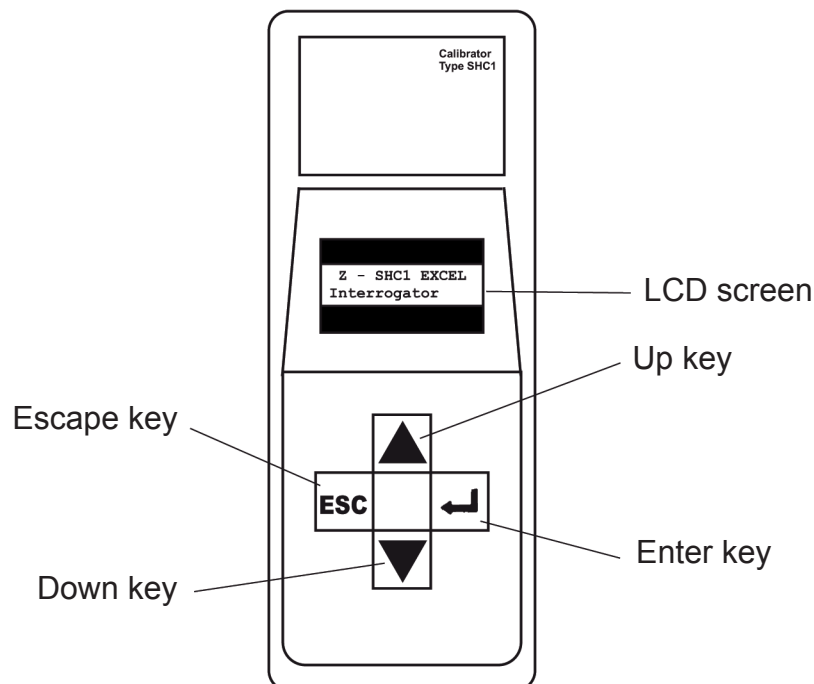

SHC1 Handheld Interrogator Main Features

APPENDIX A - HANDHELD INTERROGATOR

The interrogator is powered by a standard 9V battery and has a management system which reduces power consumption by placing the unit in an idle mode when it is waiting for user input or for a communication operation to complete.

The interrogator also features a 2k byte non-volatile RAM (NV-RAM) split into two sections. These sections are used to store the current operating mode and a backup copy.

Liquid Crystal Display Screen

This screen consists of a two-line, 16-character dot-matrix liquid crystal display (LCD). The screen displays messages which communicate information from/to the user.

It displays a menu system that enables the user to select the command mode for the system, and can also display information about the system configuration and its settings, plus any error messages.

Keypad Buttons

The four keypad buttons are used to provide operator input in response to messages shown on the display.

This includes menu option selections and changing parameter values. The four buttons are:

- ▲ Up Move to the previous menu option, list item, or increase a displayed data value.
- ▼ Down Move to the next menu option, list item, or decrease a displayed data value.
- ESC Escape Quit the current menu level or operation and return to the previous menu, e.g. stop displaying a list, abort a command. No change if already at the top level.
- ↵ Enter Select, i.e. Invoke/accept, the currently displayed menu option, list item, data value, or configuration change.

Note: If the ▲ and ▼ keys are used to advance beyond the end of a list a wrap around to the other end of the list occurs.

A.3 CONNECTION TO SYSTEM

Details of how to connect the interrogator to the Searchline Open-Path system are given in **Chapter 3**. The diagram shows a typical example.

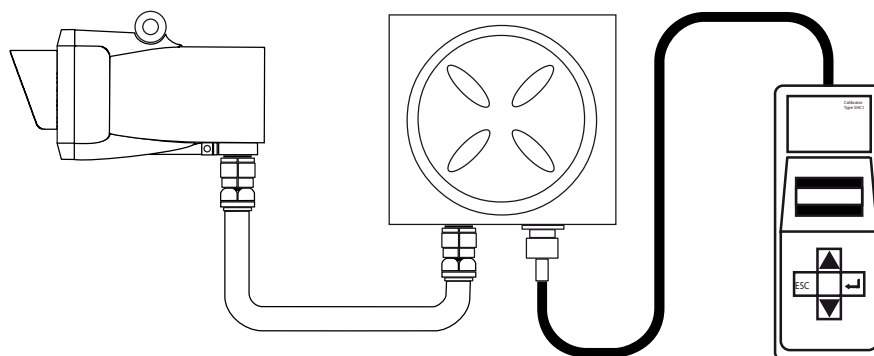

Note: If not connecting to a DX100 or OELD series termination unit the SHC Protection Device must be used.

APPENDIX A - HANDHELD INTERROGATOR

A.4 BASIC USER TASKS

Switching On

- (1) Press **↵** for two seconds.

*The unit recalls its previously set operating mode, i.e. **EXCEL**, **OPTIMA** or **OPTIMA PLUS**, and displays the following message for approximately three seconds:*

Z - SHC1 EXCEL Interrogator 4V0

The unit then displays the top level of the menu style interface in the following way:

^	Main Display	v
---	-----------------	---

During use the first line of the display shows the current level in the menu tree.

The second line displays the sub menu title, action to be invoked, or data value to be checked/changed.

*Note: To change the operating mode at switch-on, e.g. from **OPTIMA** to **EXCEL**, press the **ESC** key whilst the initial message is displayed. This changes the mode and re-displays the message.*

Switching Off

- (1) Select the **Power Off** option from the **Main Menu**,
*Alternatively press the **↵** and **ESC** buttons simultaneously for a fast power off.*

Notes:

- The unit powers down automatically after five minutes of non-use.*
- The fast power off facility and auto power off are disabled when a menu option is selected that modifies the interrogator's configuration.*

<p style="text-align: center;">CAUTION</p> <p style="text-align: center;">Only use batteries specified below. Replace the battery only in a Safe Area.</p>

To replace the battery in the Hand-Held Interrogator SHC-1 proceed as follows:

ONLY USE DURACELL MN1604 TYPE 6LR61

- (1) Remove the Interrogator from its protective pouch.
- (2) Using a 2.5mm allen hexagonal key, loosen the four screws on the rear cover of the Interrogator.

APPENDIX A - HANDHELD INTERROGATOR

- 3) Carefully lift the front half of the Interrogator away from the rear cover, ensuring the flexible connector connecting the keypad to the electronics module is not damaged.
- 4) Unclip the old battery and fit the new battery in position (re-use the protective sleeve).
- 5) Carefully replace the front half of the Interrogator back into the rear cover, ensuring the flexible connector lies flat.
- 6) Using a 2.5mm allen hexagonal key, tighten the four screws on the rear cover of the Interrogator.

When the battery reaches end of life, take it to a collection point designated by local authorities.

A.5 MENUS

The interrogator top level menu structure and menu choices are as follows.

All menu options are implemented by pressing the keypad  key. The menu options and types are shown in the diagram:

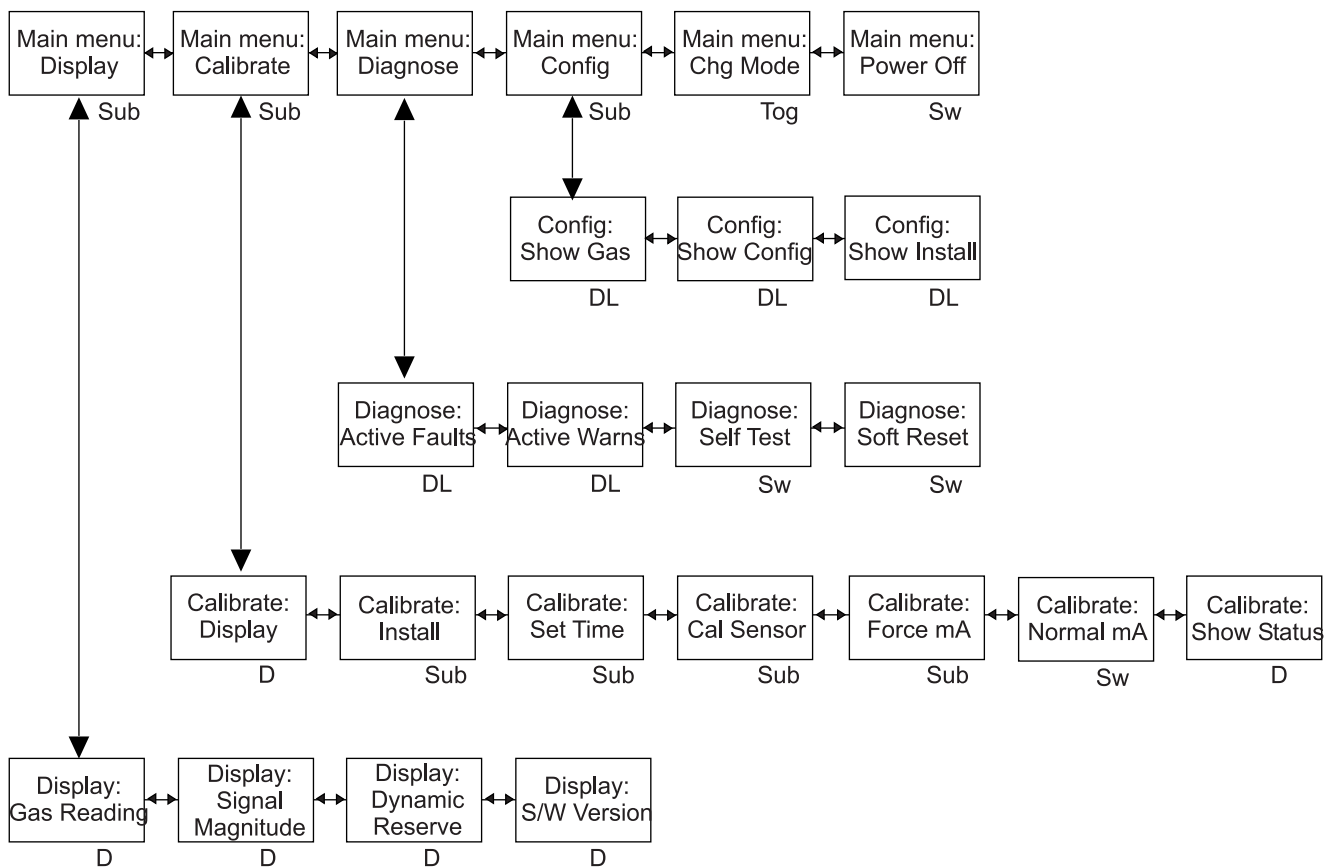

APPENDIX A - HANDHELD INTERROGATOR

where:

- D** a single set of data is displayed.
 - DL** a list of data is displayed - use the ▲ and ▼ keys to navigate the entries in the list.
 - Sub** another menu of options is displayed when this choice is selected - use the ▲ and ▼ keys to navigate the sub menu choices.
 - Sw** the displayed option is immediately activated.
 - Tog** the displayed option is toggled between three choices using the ▲ and ▼ keys.
- Chapter 3** and **Chapter 4** of this handbook describe how the Interrogator and menus are used when the system is being installed/in use.

A.5.1 Main Menu

This menu consists of the following sub menu options:

Display	Display gas and other unit readings.
Calibrate	Install and calibrate the system, force the analogue output, show the calibration coefficients or show the instrument status.
Diagnose	Inspect the fault and warning logs, perform a self-test or perform a soft reset.
Config	Read the configuration parameters of the unit, update the user configuration parameters.
Chg Mode	Toggle the operating mode of the interrogator.
Power Off	Switch the interrogator off.

A.5.2 Display Menu

This sub menu displays gas and other unit readings. It has the following options:

Gas Reading	Display the gas type and system status.
Signal magnitude	Show the level of the sample and reference signals.
Dynamic Reserve	Shows the acceptable drop in signal level before beam block occurs as a percentage of the current signal level.
S/W Version	Displays the system software version and the current time and date.

Gas Reading

Display the gas type and system status. The display is in the following format:

<pre>Excel gggggggg rrrrrr uuuu /</pre>

where: **gggggggg** Gas name. For a special gas table this shows <Gnnn> where **nnn** is the identifier.

APPENDIX A - HANDHELD INTERROGATOR

rrrrrr	Gas reading.
uuuu	Measurement units.
/	This is a status character which indicates one of the following:
normally	/ - A spinning line shows the system is operating i.e. in a fully active state.
	 - A stationery line shows the system is in an inhibit state.
	W - Active Warning.
	F - Active Fault.
	B - Beam Block.
	A - Alarm

Signal Magnitude

Show the level of the sample and reference signals. The display is in the following format:

Sample: aaaaaaa
Ref: bbbbbb

where: **aaaaaaa** Signal magnitude for the sample channel.
bbbbbb Signal magnitude for the reference channel.

Dynamic Reserve

Shows the acceptable drop in signal level before beam block occurs as a percentage of the current signal level. The display is in the following format:

Dynamic Reserve:
xxx.xx %

where: **xxx.xx** The acceptable drop in signal level before beam block measured as a percentage of the current signal level.

S/W Version

Displays the system software version and the current time and date. The display is in the following format:

Excel S/W vvVvv
hh:mm dd/mm/yy

where: **vvVvv** Version number of the Excel system software.
hh.mm System time as hours and minutes.
dd/mm/yy System date as day of the month, month number and the last two digits of the year.

Note: The year 2000 is displayed as 00.

APPENDIX A - HANDHELD INTERROGATOR

A.5.3 Calibrate Menu

This sub menu is used when installing and calibrating the system. It has the following options:

Display	Display system readings.*
Install	Direct the alignment and initialisation of the system.*
Set Time	Set the system real time clock time and date.
Cal Sensor	Calibrate the system zero.*
Force mA	Fix the 4-20mA analogue output at a selected level.
Normal mA	Restore the analogue output to its normal output state.
Show Status	Show the calibration and configuration status of the system.

The options marked with an asterisk, (*), require the system's analogue 4-20mA output to be inhibited during their operation. Where this occurs then the following sequence is automatically added to the affected operation.

Before the selected sub menu operation is started the following message is displayed for at least three seconds:

Inhibiting 4-20
Please Wait

The analogue output is inhibited and the chosen sub menu operation proceeds. After the sub menu operation is completed, or aborted by pressing the **ESC** key, the following message is displayed:

Press Enter To
Release 4-20

Press **↵** to release the 4-20 receiver output and the following message will be displayed for three seconds:

4-20 Released

Display

Display system readings. This choice is the same as the **GAS READING DISPLAY** option on the **DISPLAY MENU**.

Notes:

1. *The 4-20 output is inhibited during the display. See the earlier description.*
2. *No spinning line is displayed as the receiver is not in a fully activated state.*

Install

This choice is used to complete the alignment and commissioning operations after the system is mechanically and electrically installed. It provides a sequential set of operations to:

- **view the system type**

APPENDIX A - HANDHELD INTERROGATOR

- set the system path length
- perform a system self test
- check system alignment
- initialise the system and make it live

Note: The 4-20 output is inhibited during this procedure. See the earlier description.

System Type

The initial display after **Install** is chosen is in the following format:

```

System Type
tttttttt
    
```

where: tttttttt System type. The system type displayed is one of the following:

Display Text	System Type
Short Range	40m range system
Medium Range	120m range system
Long Range	200m range system

Note: It is not possible to change the system type. This is set during calibration and configuration of the unit at the factory.

Path Length

The following message is displayed:

```

Path Length
nnnn
    
```

where: nnnn The path length in metres.

The following ranges of path length can be entered for the system types:

System Type	Minimum Range (m)	Maximum Range (m)	Step Size (m)
Short Range	5	40	1
Medium Range	20	120	1
Long Range	120	200	1

APPENDIX A - HANDHELD INTERROGATOR

Self Test

This starts the system self test process.

The following message is displayed:

Press Enter to
Perform checks

This message is displayed during the self test process after pressing **Enter**.

Processing Data
Please Wait

This message is displayed for three seconds at the end of a successful self test process.

Checks Passed

Alignment

This starts the alignment process.

The following message is displayed:

Press Enter to
Align Unit

This message displays the system output and reference signal values.

SIG: ■
MAX: ■■

where: ■ A bar graph representing the current signal magnitude - **SIG**:
 ■■ A bar graph representing the target signal - **TGT**:

Important Notes:

- 1) *The overall objective of alignment is to maximise the **SIG** level. Maximised **SIG** corresponds to optimal alignment.*
- 2) *The Instrument Assisted Alignment (IAA) system only allows Excel to be initialised if the **SIG** level is greater than or equal to the **TGT** level when **Enter** is pressed.*
- 3) *The smallest **TGT** signal level that is initially set will be equivalent to 70% (0.700) of the signal expected for the installation's path length.*
- 4) *The **TGT** level will increase gradually if the current **SIG** level is larger than the **TGT** level. The **TGT** signal level only ever increases. If the current **SIG** level falls below the **TGT** level, **TGT** will remain at its previous highest value. In order to initialise the gas detector the **SIG** level must be brought back above the **TGT** level.*
- 5) *If the **SIG** level is less than 50% of the expected level, the bar graphs are **not** displayed. Instead both **SIG** and **TGT** levels are displayed as **numbers**.*

APPENDIX A - HANDHELD INTERROGATOR

Options

The approach to mechanical alignment depends on the type of alignment telescope and mounting initially used to set up the Excel gas detector, also see **Chapter 3**.

Bayonet-style Trident-type telescope assembly

If this type of alignment telescope was used with a Trident-type Excel gas detector, there is no need to further optimise the alignment using the SHC1 Handheld Interrogator.

When the **SIG** and **TGT** bar graphs are displayed on the SHC1 screen, **SIG** will always be greater than **TGT** and installation can proceed to the next stage by pressing **Enter** and following step 12.

Latch-style telescope assembly

If this type of alignment telescope was used with a Trident-type Excel gas detector, there is no need to further optimise the alignment using the SHC1 Handheld Interrogator.

If this type of alignment telescope was used with a non-Trident Excel it may be necessary to further optimise the alignment in the following way in order to achieve best performance.

- (a) After the **SIG** and **TGT** bar graphs are displayed on the SHC1 screen as previously described, let the **TGT** level reach its initial maximum by waiting for approximately 10 seconds.
*During this time the **TGT** level will move up towards the current **SIG** level.*
- (b) Whilst watching the **SIG** level closely, make a **small** mechanical adjustment in either the horizontal or vertical alignment and note whether the **SIG** level goes up or down.
- (c) If the **SIG** level goes **up**, make another **small** mechanical adjustment in the same direction as before.
- (d) If the **SIG** level goes **down**, change the direction of adjustment.
*Maximise the **SIG** level by making **small** adjustments in only **one plane** at a time.*
- (e) When the **SIG** level has been maximised in one plane, make small adjustments in the other plane until **SIG** has been maximised in this plane.
- (f) Repeat steps (b) to (e) until the **SIG** level has been maximised in both planes.
*At this point, **SIG** must be bigger than the initial **TGT** level and any adjustment either side of the current alignment must result in a reduction in signal level.
If not, repeat steps (b) to (e) until these requirements have been met.*
- (g) Lock off the alignment by placing a hex (Allen) key in the pair of grub-screws which control adjustment in a particular plane and simultaneously rotating them in opposite directions.
- (h) Repeat this for the other pair of grub-screws.
- (i) Press **Enter** and the signal levels are checked.

APPENDIX A - HANDHELD INTERROGATOR

Provided that the **SIG** level is greater than the **TGT** level, the signal check should pass on to the next stage of installation.

Initialisation

This starts the initialisation process. The following message is displayed:

Press Enter to
Initialise Unit

This message is displayed during the initialisation process after pressing **Enter**.

Processing Data
Please Wait

This message is displayed for three seconds at the end of a successful initialisation process.

Unit Initialised

*Note: The Searchline Excel system is **live** after a successful initialisation.*

Set Time

This option lets you set the system's time and date.

The initial display after **SET Time** is chosen is in the following format:

Time HH:MM
hh:mm

where: **hh** Hours.
 mm Minutes.

When first displayed only the current hour is shown.

All settings are adjusted by means of the ▲ and ▼ keys on the keypad.

After setting the hour the minutes are displayed.

After the time has been entered then the same process is used to set the date which is displayed in the following format:

Date DD/MM/YY
dd/mm/yy

where: **dd** Day.
 mm Month.
 yy Last two digits of the year.

APPENDIX A - HANDHELD INTERROGATOR

Notes:

1. The time and date will not be updated unless both are entered and accepted without error.
2. The year 2000 is displayed as 00.

Cal Sensor

This menu option zeros the system.

Notes:

1. The 4-20 output is inhibited during this procedure. See the earlier description.
2. There must be no gas in the system beam path whilst this procedure is carried out.

The following message is displayed:

Ensure Zero Gas
Press Enter

The following message is displayed while the calibration operation is being performed:

Processing Data
Please Wait...

If the calibration is successful, the following message is displayed for a period of three seconds:

Zero Calibrated

Force mA

▲

▼

This option allows the system's analogue output signal to be adjusted to a fixed level, e.g. when setting up a system controller. The following message is displayed:

O/P current mA
mmmmmm

where: mmmmm Current to output.

This is adjusted using the ▲ and ▼ keys over the range 1mA to 21mA in steps of 0.1mA.

After adjustment the output is forced to the set level and the following message is displayed:

Fixed: mmmmm mA
Press Enter

where: mmmmm Analogue output current previously set.

APPENDIX A - HANDHELD INTERROGATOR

Normal mA

This menu option returns the system to its normal analogue output state, irrespective of its previous state. If successful, the following message is displayed for three seconds:

4-20mA Released

Show Status

This menu option displays the calibration and configuration status of the system. The status information is displayed in the following format:

cccccccccccccccc
ssssssss

where: cccccccc . . . Title of the calibration status field.
 ssssssssss Current state of calibration.

The different settings from the list are selected using the ▲ and ▼ keys on the keypad.

The calibration status fields and values are given below:

Calibration Status Fields	Display Text	False State	True State
Temperature Cal.	Temp Sensor	Uncalibrated	Calibrated
Zero Calibration	Zero Ratio	Uncalibrated	Calibrated
Span Calibration	Span Sensitivity	Uncalibrated	Calibrated
4-20mA Calibration	Analogue Output	Uncalibrated	Calibrated
Det. Temp. Comp.	T Compensation	Uncalibrated	Calibrated
Det. Sens. Comp.	Det Sensitivity	Uncalibrated	Calibrated
Installation	Installation	Required	Complete
Valid Date Time	Date and Time	Estimated	Set
Loop Test	Analogue Check	Failed	Passed

A.5.4 Diagnose Menu

This sub menu has the following options:

- Active Faults** Display the active faults in the system.
- Active Warns** Display the active warnings in the system.
- Self Test** Perform a diagnostic system self test.
- Soft Reset** Reset the system.

Active Faults

This menu option displays operational faults when the system is in service.

If there are one or more faults present, then the faults are displayed one at a time.

Use the ▲ and ▼ keys to navigate the list.

APPENDIX A - HANDHELD INTERROGATOR

If no active faults are present the display shows the following for three seconds:

None Present

The **Diagnose** sub menu is then displayed.

If there are one or more faults present, the display shows:

F-hh:mm DD/MM/YY
eeeeeeeeeeeeeeee

where: **F** Indicates that the message displayed is a fault.
hh:mm Time the fault occurred.
DD/MM/YY Date the fault occurred.
eeeeeee . . . Fault description. See the following table for a list of error messages.

See also **Chapter 5, Problem Solving.**

Display Text	Fault Description	Meaning
Bad 4-20mA Loop	ERR_EXCEL_LOOP_FAULT	A fault has occurred in the 4-20mA signal loop.
DSP Fault	ERR_EXCEL_DSP_FAULT	Fault on the gas detector's digital PCB.
Hardware Fault	ERR_EXCEL_HW_FAULT	A hardware fault has occurred.
NV-RAM Fault	ERR_EXCEL_FRAM_FAULT	A fault has been detected in the unit's NV-RAM.
RTC Fault	ERR_EXCEL_RTC_FAULT	The time and date record stored by the RealTime Clock (RTC) has been lost.
Software Fault	ERR_EXCEL_SW_FAULT	An gas detector software error has occurred.
Supply Fault	ERR_EXCEL_SUPPLY_FAULT	Incorrect supply voltage reaching the gas detector.

Active Warns

This menu option displays the active warnings in the system. They are displayed in the same way as described for **Active Faults** except that a **W** is displayed instead of **F** on the first line of the display.

Display Text	Fault Description	Meaning
Alarm	ERR_EXCEL_LOG_ALARM	The Excel log has become damaged.
Bad Temperature	ERR_EXCEL_TEMPERATURE_LIMIT	Unit has been operated at a temperature outside its specified and certified range.
Baseline Drift	ERR_EXCEL_DRIFT_LIMIT	Drift of unit's baseline.
Beam Blocked	ERR_EXCEL_BEAM_BLOCKED	The infrared beam between the Transmitter and Receiver has become blocked.
Neg Gas Reading	ERR_EXCEL_NEGATIVE_DRIFT	Negative drift of gas detector's zero position.
Not Installation	ERR_EXCEL_BAD_INSTALLATION	Incorrect gas detector installation has occurred.
Overrange	ERR_EXCEL_OVERRANGE	An overrange signal has occurred.
Power Failed	ERR_EXCEL_LOG_POWER_FAIL	The gas detector has suffered an internal power failure.

APPENDIX A - HANDHELD INTERROGATOR

Reset Occurred	ERR_EXCEL_RESET	A gas detector reset has occurred.
Time Adjusted	ERR_EXCEL_LOG_TIME_ADJUST	The Excel log time has been changed.
Uncalibrated	ERR_EXCEL_UNCALIBRATED	The gas detector requires calibration.
Volt Ref Fault	ERR_EXCEL_VOLTAGE_REF_FAIL	Voltage reference fault detected.

Self Test

This option lets you start a system diagnostic self test.

The following message is displayed during the self test process:

**Processing Data
Please Wait**

The following message is displayed for three seconds at the end of a successful self test process.

Checks Passed

Soft Reset

This option lets you reset the system.

This message is displayed during the reset process:

**Processing Data
Please Wait**

The following message is displayed for three seconds when the process is completed:

Unit Reset

A.5.5 Config Menu

This sub menu lets you check the configuration parameters of the unit and update the user configuration parameters. It has the following options:

- Show Gas** Show the gas related configuration parameters.
- Show Config** Show the user related configuration parameters.
- Show Install** Show the installation related configuration parameters.

APPENDIX A - HANDHELD INTERROGATOR

Show Gas

This option displays the useful gas table configuration parameters in the following way:

cccccccccccccccc vvvvvvvvv

where: ccccccc . . . Title of the configuration setting.
 vvvvvvvvv Setting value.

Note: The settings are not field configurable:

Gas Configuration Parameters Step Size	Display Text	Min Value	Max Value
Gas ID	Gas Ident	0	255
		1 = Methane	1
		2 = Ethane	
		3 = Propane	
		4 = Butane	
		5 = Pentane	
		6 = Hexane	
		7 = Methane (%UEGm)	
		8 = Ethane (%UEGm)	
		9 = Propane (%UEGm)	
		10 = Butane (%UEGm)	
		11 = Pentane (%UEGm)	
		12 = Hexane (%UEGm)	
		20 = Methane	
		21 = Ethane	
		22 = Propane	
		23 = Butane	
		24 = Pentane	
		25 = Hexane	
		26 = Ethylene	
		27 = Propylene	
		28 = Butadiene	
		29 = Ethanol	
		30 = Methanol	
		31 = Methane (%UEGm)	
		32 = Ethane (%UEGm)	
		33 = Propane (%UEGm)	
		34 = Butane (%UEGm)	
		35 = Pentane (%UEGm)	
		36 = Hexane (%UEGm)	

APPENDIX A - HANDHELD INTERROGATOR

Gas Units	Gas Units	LELm, PPMm, UEGm, or VVm %LEL (Cross-Duct only)
Effective Full Scale	Gas Full Scale	0.1 100000 0.05

37 = Ethylene (%UEGm)
38 = Propylene (%UEGm)
39 = Butadiene (%UEGm)
40 = Ethanol (%UEGm)
41 = Methanol (%UEGm)

Show Config

This option displays the configuration parameters the user can set in the same way as for the **Show Gas** option. The configurable settings and values are shown in the following table:

Configuration Parameters	Display Text	Min Value	Max Value	Step Size	Default Values
Protocol Address	Digital Address	0	255	1	0
Time to Block	Block Warn Time	5s	600s*	5s	30s
Time to Fault	Block Fault Time	0s	600s	5s	120s
Max Response	Maximum T90	1s	60s	1s	60s
Analogue Style	Analogue Mode	Alarm or Continuous			C
Inhibit Current	Inhibit mA	0mA	3mA	0.05mA	2.0mA
Block Current	Blocked mA	0mA	4mA	0.05mA	2.5mA
Low Signal Current	Low Signal mA	0mA	4mA	0.05mA	3.0mA
Low Signal Level	Low Signal %	0%	90%	1%	33%
Alarm Threshold	Alarm Threshold	10%	100%	1%	20%
Report fault due to blockage	RPRT Blocked Fault	Enable or Disable			E

* To comply with FM performance approval, the maximum value for Time to Block is 200 s.

Show Install

This option displays the installation configuration parameters in the same way as for the **Show Gas** option. The configurable settings and values are shown below:

Installation Configuration Parameters	Display Text	Description
System Type	System Type	Short Range Medium Range Long Range Duct Mount
Path Length	Path Length	5m min. 200m max. 1m step 0.5m min. 5m max. 0.1m step

APPENDIX A - HANDHELD INTERROGATOR

A.5.6 Chg Mode

This menu option toggles the operating mode of the interrogator between **Excel**, **Optima** and **Optima Plus** to match the gas detector it is attached to. When invoked the mode is displayed in the identification banner (the same as the one displayed when the unit is switched on) for three seconds as follows:

Z - SHC1 aaaaaa Interrogator 4V0

where: aaaaaa The type of gas detector that the interrogator is currently set to, i.e. **Excel**, **OPTIMA** or **OPTIMA PLUS**.

A.5.7 Power Off

This menu option switches the interrogator off.

Alternatively press the ↵ and ESC buttons simultaneously for a fast power off.

Notes:

- 1. The unit powers down automatically after five minutes of non-use.*
- 2. The fast power off facility and auto power off are disabled when a menu option is selected that modifies the unit's configuration.*

APPENDIX A - HANDHELD INTERROGATOR

A.6 PROBLEM SOLVING

Interrogator problems that occur during communication with the system or as a result of a command failure will be displayed in the following format:

Error: eee ssssssssssssssssss

where: **eee** Error code.
ssssssss . . . Textual description of the error.

If an error message of this kind is displayed note down the error code and text description and contact Honeywell Analytics.

A.7 SPECIFICATION

A.7.1 HAND-HELD INTERROGATOR SHC-1 SPECIFICATION

CERTIFICATION:

ATEX & IECEx: EN60079-0:2012, EN60079-11:2012
IEC60079-0:2011
IEC60079-11 2011
ATEX: Baseefa03ATEX0073.
IECEX: BAS 09.0120
⊕ II 2G Ex ia IIC T4 Gb

○	Honeywell Analytics Ltd Poole BH17 0RZ UK	○									
	CALIBRATOR TYPE SHC 1										
	⊕ II 2 G Ex ia IIC T4 Gb (Tamb -40°C to +40°C)										
	Baseefa03ATEX0073X										
Ⓢ Ⓢ 1180	IECEX BAS 09.0120										
	PART No. 04230-A-XXXX										
	SER. No. 0X/XXXXX										
	READ AND UNDERSTAND MANUAL BEFORE USE.										
○	Mod. <table border="1"><tr><td>1</td><td>2</td><td>3</td><td>4</td><td>5</td><td>6</td><td>7</td><td>8</td><td>9</td></tr></table>	1	2	3	4	5	6	7	8	9	○
1	2	3	4	5	6	7	8	9			

APPENDIX A - HANDHELD INTERROGATOR

	Tamb -40°C to +40°C
OPERATING TEMPERATURE RANGE:	0°C to +40°C (DMT evaluated: -25°C to +55°C)
STORAGE TEMPERATURE RANGE:	-10°C to +40°C
OPERATING HUMIDITY:	0 to 99% RH
DIMENSIONS:	Long: 190mm Depth: 40mm Width: 80mm
WEIGHT:	0.5kg
MATERIAL:	Stainless Steel ANSI 316

A.7.2 SHC PROTECTION DEVICE

WARNING
Not Certified for use in hazardous areas.
Not DMT evaluated.

OPERATING TEMPERATURE RANGE:-	40°C to +65°C
OPERATING HUMIDITY:	0 to 99% RH
DIMENSIONS:	
Lead Length:	Long: 670mm
Box Dimensions:	Long: 78mm Depth: 39mm Width: 59mm
WEIGHT:	0.2kg
MATERIAL:	High Impact ABS

A.7.3 TERMINATION UNIT DVC100M MK2 SPECIFICATION

CERTIFICATION:

ATEX & IECEx:	EN60079-0, EN60079-7, EN60079-11, EN61241-18, IEC60079-0:2004 Ed.4, IEC60079-11:2006 Ed.5, IEC60079-18:2004 Ed.2 AND IEC60079-7:2001 Ed.3. EEx ia IIC T6 amb -40°C to +65°C
---------------	-----------------------------------------------------------------------------------------------------------------------------------------------------------------------------------------

APPENDIX A - HANDHELD INTERROGATOR

OPERATING TEMPERATURE RANGE:	-40°C to +65°C (DMT evaluated: -25°C to +55°C)
STORAGE TEMPERATURE:	-10°C to +40°C
OPERATING HUMIDITY:	0 to 99% RH (DMT evaluated: 5% to 90% RH)
DIMENSIONS:	Long: 160mm Depth: 90mm Width: 160mm
WEIGHT:	2.0kg
MATERIAL:	DMC reinforced polyester
EMC COMPLIANCE:	EN50270, susceptibility to 20V/m (DMT evaluated up to 3V/m)

APPENDIX B - GLOSSARY

B.1 TERMINOLOGY

Ex d

Flame proof or explosion proof within the confines of European standards EN60079-0 and EN60079-1. An enclosure that can withstand the pressure developed during the internal explosion of an explosive mixture and that prevents transmission of the explosion to the explosive atmosphere surrounding the enclosure.

Ex op is

Protection of equipment using Optical Radiation (IEC / EN 60079 – 28). Optical energy and power are limited to levels that are incapable of igniting a flammable or explosive dust atmosphere. The term Ex op is is not to be confused with the term IS described below.

Ex e

Increased safety within the confines of European standards EN60079-0 and EN60079-7 applied to electrical apparatus that does not produce arcs or sparks in normal service, in which additional measures are applied so as to give increased security against the possibility of excessive temperatures.

Instrument Assisted Alignment (IAA)

A method of commissioning the Excel system using the associated electronic Handheld Interrogator device. The process will not allow the Excel system to initialise unless the alignment of the Receiver and Transmitter is correct and the signal strength is correct.

IS

Intrinsically safe, apparatus in which the circuits themselves are incapable of causing ignition of a flammable gas.

Lower Explosive Limit (LEL)

The volume of flammable gas or vapour in air below which an explosive gas atmosphere will not be formed.

RS485

An industry-wide serial communication link protocol.

Turbo heating

Increased Transmitter window heating at low operating temperatures.

B.2 MEASUREMENT UNITS

Open path detectors measure the amount of gas present in the beam. However, they cannot discriminate between a low concentration gas cloud over a large area and a high concentration gas cloud in a small area.

APPENDIX B - GLOSSARY

Generally, gas readings of LEL.m (Lower Explosive Limit metres) are used. LEL.m is calculated by multiplying the size of a gas cloud by its concentration.

An open path alarm set at 1 LEL.m would be triggered by any of the situations shown below:

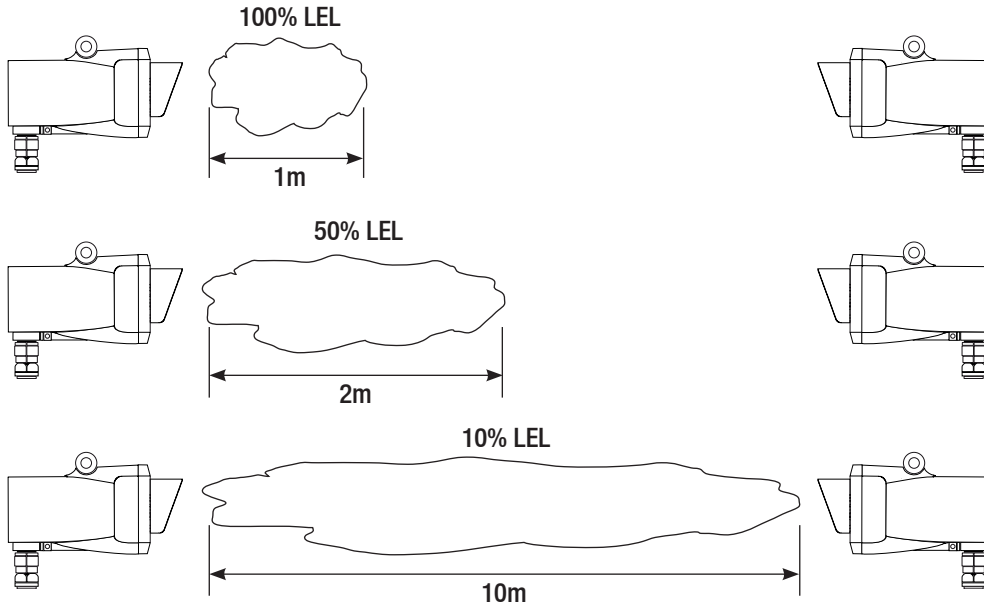

LEL.m monitoring is particularly beneficial while the Excel gas detector is protecting the perimeter of a plant or process, often reducing the quantity of point detectors required. The open path LEL.m system has the ability to detect leaks that point detectors may miss due to prevailing or changing wind directions, and can provide early warning of a dilute gas cloud when point detectors may not register any gas presence.

To decide on alarm set points, it is recommended that the user firstly determine the size of gas cloud that they wish to protect against, then set the alarm point to a fraction not greater than 60% of that cloud size. For example, to protect against a 5 m cloud, set the alarm point ≤ 3 LELm.

B.3 ABBREVIATIONS

ATEX	European Hazadous Area Approval
CSA	Canadian Standards Association
DNV	Det Norske Veritas
DSP	Digital Signal Processor
EMC	Electro-Magnetic Compatibility
FM	Factory Mutual
IAA	Instrument Assisted Alignment
IECEX	International Hazadous Area Approval

APPENDIX B - GLOSSARY

IP	Ingress Protection
IR	Infrared
IS	Intrinsically Safe
LEL	Lower Explosive Limit
LR	Long Range
MR	Medium Range
NPT	National Pipe Thread
RFI	Radio Frequency Interference
RoHS	Restriction of Hazardous Substances
SHC	Sieger Handheld Calibrator
SR	Short Range
UL	Underwriters Laboratories

APPENDIX C - ACCESSORIES & SPARE PARTS

C.1 SYSTEM UNITS

The following table lists the different types of system units and provides the part numbers for the various certification options.

All types of Transmitters and Receivers include conduit and glands. Open-Path Transmitters and Receivers do not include mounting plates and brackets.

Instrument	
Searchline Excel Short Range 5m – 40m (15ft - 130ft)	
Part Number	Description
02104-N-4014	Short range system, 4 to 20mA (source) and Modbus outputs, ATEX/IECEEx, fully wired with flexible conduit, electro polished 316SS. Includes Tx, Rx, 2 x Ex e junction boxes with M20/M25 cable entries, 316SS mounting plates, brackets and hardware
02104-N-4044	Short range system, 4 to 20mA (sink) and Modbus outputs, ATEX/IECEEx, fully wired with flexible conduit, electro polished 316SS. Includes Tx, Rx, 2 x Ex e junction boxes with M20/M25 cable entries, 316SS mounting plates, brackets and hardware
02104-N-5012	Short range system, 4 to 20mA (source) and Modbus outputs, UL, fully wired with flexible conduit, electro polished 316SS. Includes Tx, Rx, DX100 termination unit and junction box, 3/4"NPT cable entries, 316SS mounting plates, brackets, hardware and sunshade finished with white painted finish.
02104-N-5042	Short range system, 4 to 20mA (sink) and Modbus outputs, UL, fully wired with flexible conduit, electro polished 316SS. Includes Tx, Rx, DX100 termination unit and junction box, 3/4"NPT cable entries, 316SS mounting plates, brackets, hardware and sunshade finished with white painted finish.
02104-N-6012	Short range system, 4 to 20mA (source) and Modbus outputs, FM/CSA, fully wired with flexible conduit, electro polished 316SS. Includes Tx, Rx, DX100 termination unit and junction box, 3/4"NPT cable entries, 316SS mounting plates, brackets, hardware and sunshade finished with white painted finish.
02104-N-6042	Short range system, 4 to 20mA (sink) and Modbus outputs, FM/CSA, fully wired with flexible conduit, electro polished 316SS. Includes Tx, Rx, DX100 termination unit and junction box, 3/4"NPT cable entries, 316SS mounting plates, brackets, hardware and sunshade finished with white painted finish.
02104-N-7012	Short range system, 4 to 20mA (source) and Modbus outputs, Inmetro, fully wired with flexible conduit, electro polished 316SS. Includes Tx, Rx, DX100 termination unit and junction box, 3/4"NPT cable entries, 316SS mounting plates, brackets, hardware and sunshade finished with white painted finish.
02104-N-7042	Short range system, 4 to 20mA (sink) and Modbus outputs, Inmetro, fully wired with flexible conduit, electro polished 316SS. Includes Tx, Rx, DX100 termination unit and junction box, 3/4"NPT cable entries, 316SS mounting plates, brackets, hardware and sunshade finished with white painted finish.
02104-N-NSNM	Short range system, 4 to 20mA (source) and Modbus outputs, ATEX/IECEEx, fully wired with flexible conduit, electro polished 316SS. Includes Tx, Rx, 2 x Ex e junction boxes with M20/M25 cable entries, DNV-approved 316SS mounting plates, brackets and hardware

APPENDIX C - ACCESSORIES & SPARE PARTS

Searchline Excel Medium Range 40m – 120m (130ft - 390ft)	
02104-N-4024	Medium range system, 4 to 20mA (source) and Modbus outputs, ATEX/IECEEx, fully wired with flexible conduit, electro polished 316SS. Includes Tx, Rx, 2 x Ex e junction boxes with M20/M25 cable entries, 316SS mounting plates, brackets and hardware
02104-N-4054	Medium range system, 4 to 20mA (sink) and Modbus outputs, ATEX/IECEEx, fully wired with flexible conduit, electro polished 316SS. Includes Tx, Rx, 2 x Ex e junction boxes with M20/M25 cable entries, 316SS mounting plates, brackets and hardware
02104-N-5022	Medium range system, 4 to 20mA (source) and Modbus outputs, UL, fully wired with flexible conduit, electro polished 316SS. Includes Tx, Rx, DX100 termination unit and junction box, 3/4"NPT cable entries, 316SS mounting plates, brackets, hardware and sunshade finished with white painted finish.
02104-N-5052	Medium range system, 4 to 20mA (sink) and Modbus outputs, UL, fully wired with flexible conduit, electro polished 316SS. Includes Tx, Rx, DX100 termination unit and junction box, 3/4"NPT cable entries, 316SS mounting plates, brackets, hardware and sunshade finished with white painted finish.
02104-N-6022	Medium range system, 4 to 20mA (source) and Modbus outputs, FM/CSA, fully wired with flexible conduit, electro polished 316SS. Includes Tx, Rx, DX100 termination unit and junction box, 3/4"NPT cable entries, 316SS mounting plates, brackets, hardware and sunshade finished with white painted finish.
02104-N-6052	Medium range system, 4 to 20mA (sink) and Modbus outputs, FM/CSA, fully wired with flexible conduit, electro polished 316SS. Includes Tx, Rx, DX100 termination unit and junction box, 3/4"NPT cable entries, 316SS mounting plates, brackets, hardware and sunshade finished with white painted finish.
02104-N-7022	Medium range system, 4 to 20mA (source) and Modbus outputs, Inmetro, fully wired with flexible conduit, electro polished 316SS. Includes Tx, Rx, DX100 termination unit and junction box, 3/4"NPT cable entries, 316SS mounting plates, brackets, hardware and sunshade finished with white painted finish.
02104-N-7052	Medium range system, 4 to 20mA (sink) and Modbus outputs, Inmetro, fully wired with flexible conduit, electro polished 316SS. Includes Tx, Rx, DX100 termination unit and junction box, 3/4"NPT cable entries, 316SS mounting plates, brackets, hardware and sunshade finished with white painted finish.
Searchline Excel Long Range 120m – 200m (390ft - 650ft)	
02104-N-4034	Long range system, 4 to 20mA (source) and Modbus outputs, ATEX/IECEEx, fully wired with flexible conduit, electro polished 316SS. Includes Tx, Rx, 2 x Ex e junction boxes with M20/M25 cable entries, 316SS mounting plates, brackets and hardware
02104-N-4064	Long range system, 4 to 20mA (sink) and Modbus outputs, ATEX/IECEEx, fully wired with flexible conduit, electro polished 316SS. Includes Tx, Rx, 2 x Ex e junction boxes with M20/M25 cable entries, 316SS mounting plates, brackets and hardware
02104-N-5032	Long range system, 4 to 20mA (source) and Modbus outputs, UL, fully wired with flexible conduit, electro polished 316SS. Includes Tx, Rx, DX100 termination unit and junction box, 3/4"NPT cable entries, 316SS mounting plates, brackets, hardware and sunshade finished with white painted finish.

APPENDIX C - ACCESSORIES & SPARE PARTS

02104-N-5062	Long range system, 4 to 20mA (sink) and Modbus outputs, UL, fully wired with flexible conduit, electro polished 316SS. Includes Tx, Rx, DX100 termination unit and junction box, 3/4"NPT cable entries, 316SS mounting plates, brackets, hardware and sunshade finished with white painted finish.
02104-N-6032	Long range system, 4 to 20mA (source) and Modbus outputs, FM/CSA, fully wired with flexible conduit, electro polished 316SS. Includes Tx, Rx, DX100 termination unit and junction box, 3/4"NPT cable entries, 316SS mounting plates, brackets, hardware and sunshade finished with white painted finish.
02104-N-6062	Long range system, 4 to 20mA (sink) and Modbus outputs, FM/CSA, fully wired with flexible conduit, electro polished 316SS. Includes Tx, Rx, DX100 termination unit and junction box, 3/4"NPT cable entries, 316SS mounting plates, brackets, hardware and sunshade finished with white painted finish.
02104-N-7032	Long range system, 4 to 20mA (source) and Modbus outputs, INMETRO, fully wired with flexible conduit, electro polished 316SS. Includes Tx, Rx, DX100 termination unit and junction box, 3/4"NPT cable entries, 316SS mounting plates, brackets, hardware and sunshade finished with white painted finish.
02104-N-7062	Long range system, 4 to 20mA (sink) and Modbus outputs, INMETRO, fully wired with flexible conduit, electro polished 316SS. Includes Tx, Rx, DX100 termination unit and junction box, 3/4"NPT cable entries, 316SS mounting plates, brackets, hardware and sunshade finished with white painted finish.
Alternative Calibrations	
Excel calibration gas table. Additional costs for non standard calibrations	
2104D5026	Methane / LEL.m
2104D5002	Ethane / LEL.m
2104D5003	Propane / LEL.m
2104D5004	Butane / LEL.m
2104D5005	Pentane / LEL.m
2104D5021	Ethylene / LEL.m
2104D5022	Propylene / LEL.m
2104D5023	Butadiene / LEL.m
Alignment Kits	
02104-N-4006	Short range alignment and conformity kit including handheld interrogator, telescope, carry case and test filters for ATEX approved systems
02104-N-4006X	Short range alignment and conformity kit for XNX and OELD. Includes telescope, carry case and test filters (hand-held interrogator not included)
02104-N-4007	Medium/long range alignment and conformity kit including handheld interrogator, telescope, carry case and test filters for ATEX approved systems
02104-N-4007X	Medium/long range alignment and conformity kit for XNX and OELD. Includes telescope, carry case and test filters (hand-held interrogator not included)
02104-N-5006	Short range alignment and conformity kit including handheld interrogator, telescope, carry case and test filters for UL approved systems

APPENDIX C - ACCESSORIES & SPARE PARTS

02104-N-5007	Medium/long range alignment and conformity kit including handheld interrogator, telescope, carry case and test filters for UL approved systems
02104-N-6006	Short range alignment and conformity kit including handheld interrogator, telescope, carry case and test filters for CSA approved systems
02104-N-6007	Medium/long range alignment and conformity kit including handheld interrogator, telescope, carry case and test filters for CSA approved systems
Accessories	
Handheld Interrogator and accessories	
04230-A-1001	Hand Held Interrogator ATEX Certified (4V0 software) for Optima, Optima Plus and Excel
2104B2351	Hand Held Interrogator UL Certified (4V0 software) for Optima, Optima Plus and Excel
2104B2354	Hand Held Interrogator CSA Certified (4V1 software) for Optima, Optima Plus and Excel
2108B1455	Hand Held EEPROM upgrade (4V0)
04230-A-1025	SHC protection device module and lead
2104B6250	SHC Calibrator Connector System 10m
Termination Units	
OELDBXXXXX-ADMAX	OELD Smart Junction Box, ATEX/IECEX Ex d, 5 x M25 entries, Aluminium
OELDBXXXXX-SDMAX	OELD Smart Junction Box, ATEX/IECEX Ex d, 5 x M25 entries, SST
OELDBXXXXX-AEMAX	OELD Smart Junction Box, cULus Class I Div. 1 Zone 1, 5 x 3/4" NPT, Aluminium
OELDBXXXXX-SEMAX	OELD Smart Junction Box, cULus Class I Div. 1 Zone 1, 5 x 3/4" NPT, SST
00780-A-0100	Honeywell Junction Box- Bartec OTB122 With Continuity Plate 1 X 25mm - 3 X 20mm Entries - ATEX Approved
157-001-121	Stainless Steel (316) Junction Box, ATEX Ex d Zone1, 1xM20 & 1xM20 @90°
157-001-122	Stainless Steel (316) Junction Box, 2xM20 & 1xM25
2104B2382	DX100M XP Termination Unit UL/CSA with Modbus capability
210-190-045	Killark Junction Box (excludes terminals)
Installation Accessories	
2104D0295	Sun/Heat Shade/Deluge Cover (suitable for both standard and Maritime Brackets)
94000-A-1017	XNX/Excel receiver & transmitter sunshade kit with fixing bolts in 316SST painted white - fits standard Excel mounting plate
2992A0071	Conduit Assembly for Excel UL certified
0230-0069	Stainless Steel enclosure NEMA 4X 3/4" NPT UL
90083-A-8055	Excel Kit 4 off 6" U-Bolts x M8 C/W Nuts and Washers 316SST. For Use with Standard Mounting Plate
90083-A-8034	2 x 2" U-Bolts x M6 C/W Nuts and Washers 316SST (Note: Please order 4 pcs per Excel)
90082-A-5020	Excel SR snow cover

90082-A-5024	Excel MR / LR snow cover
Gas Test Equipment	
2104N2999	Excel Test filters kit & Manual
2104B2326	Gassing Cell
Spares	
2104B2391	Short Range Telescope (bayonet/trident fitting)
2104B2322	Medium / Long Range Telescope (calliper fitting)
2104B0300	Searchline Excel Isolation Kit Short Range
2104B0310	Searchline Excel Isolation Kit Medium/Long Range
2104B2301	Mounting Bracket Short Range & Insul. Kit
2104B2302	Mounting Bracket Long Range & Insul. Kit
2104D0237	Mounting Plate
2104B2071	Short Range Transmitter ATEX
2104B2081	Medium Range Transmitter ATEX
2104B2091	Long Range Transmitter ATEX
2104B2111	Short Range Receiver ATEX Source
2104B2112	Short Range Receiver ATEX Sink
2104B2131	Medium Range Receiver ATEX Source
2104B2132	Medium Range Receiver ATEX Sink
2104B2151	Long Range Receiver ATEX Source
2104B2152	Long Range Receiver ATEX Sink
2104B3001	Short Range Transmitter UL
2104B3011	Medium Range Transmitter UL
2104B3021	Long Range Transmitter UL
2104B3101	Short Range Receiver UL Source
2104B3102	Short Range Receiver UL Sink
2104B3111	Medium Range Receiver UL Source
2104B3112	Medium Range Receiver UL Sink
2104B3121	Long Range Receiver UL Source
2104B3122	Long Range Receiver UL Sink
2104B3201	Short Range Transmitter CSA
2104B3211	Medium Range Transmitter CSA
2104B3221	Long Range Transmitter CSA
2104B3301	Short Range Receiver CSA Source
2104B3302	Short Range Receiver CSA Sink
2104B3311	Medium Range Receiver CSA Source
2104B3312	Medium Range Receiver CSA Sink
2104B3321	Long Range Receiver CSA Source
2104B3322	Long Range Receiver CSA Sink

2104B3401	Short Range Transmitter Inmetro
2104B3411	Medium Range Transmitter Inmetro
2104B3421	Long Range Transmitter Inmetro
2104B3501	Short Range Receiver Inmetro Source
2104B3502	Short Range Receiver Inmetro Sink
2104B3511	Medium Range Receiver Inmetro Source
2104B3512	Medium Range Receiver Inmetro Sink
2104B3521	Long Range Receiver Inmetro Source
2104B3522	Long Range Receiver Inmetro Sink

APPENDIX D - MARINE BRACKET

D.1 OVERVIEW

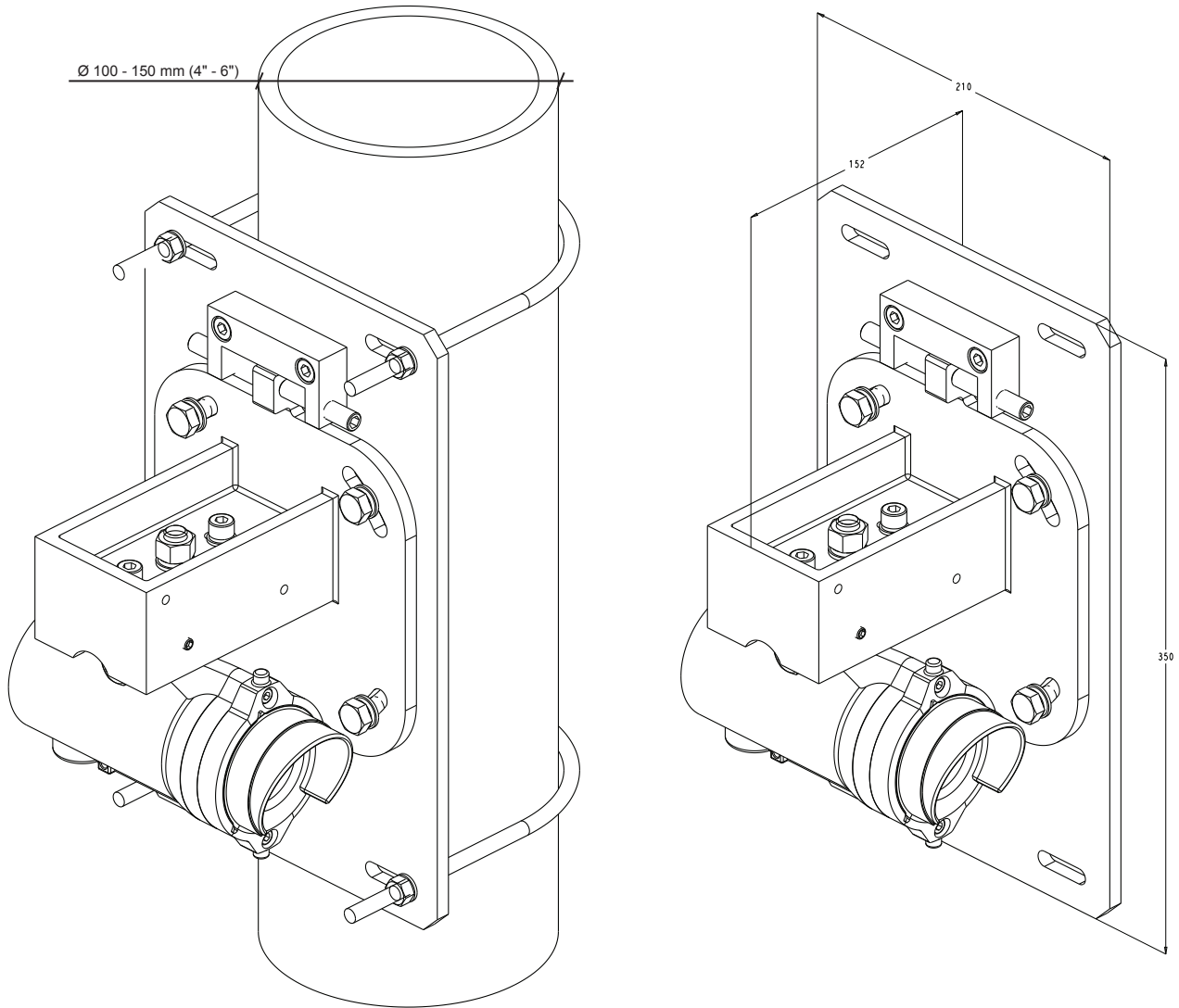

Marine Bracket general view and dimensions

APPENDIX D - MARINE BRACKET

D.2 INSTALLATION AND OPERATION

D.2.1 Unpacking

- (1) Carefully unpack the equipment, observing any instructions that may be printed on or contained within the packaging.
- (2) Check the contents for damage and against the packing note for deficiencies.

In the event of damage or loss in transit, notify the carrier and Honeywell Analytics or your local agent immediately.

The Marine Bracket consists of the following items:

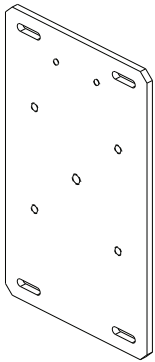

1 x Mounting Plate

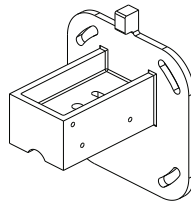

1 x Mounting Bracket

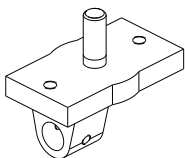

1 x Pivot Block

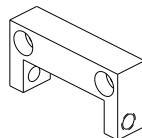

1 x Vertical Adjustment Assembly

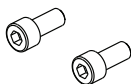

2 x Socket Cap Screw M8x18

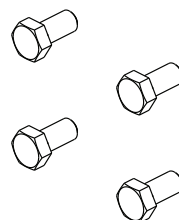

4 x Screw M10x20

APPENDIX D - MARINE BRACKET



4 x Spring Washer M10



1 x Hex Nut M12



4 x Washer M10



1 x Pivot

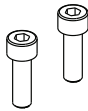

2 x Socket Cap Screw M8x25



1 x Spring Washer M12



1 x Washer M12



2 x Spring Washer M8



2 x Washer M8



2 x Hexagon Socket Screw M6x20

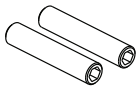

2x Hexagon Socket Screw M10x50

(3) Ensure that the installer/end user of the equipment receives the technical documentation (operating instructions, manuals, etc.) contained in the packaging.

APPENDIX D - MARINE BRACKET

D.2.2 Installation Procedure

D.2.2.1 General

The Marine Bracket is to be used in installations where compliance to the DNV Maritime Standards are required. The bracket is supplied as part of a specific Searchline Excel kit for this application.

To ensure full compliance with the DNV standard, do not modify or interchange parts from the standard Searchline Excel brackets and carefully follow the instructions contained within in this section.

D.2.2.2 Mechanical Installation

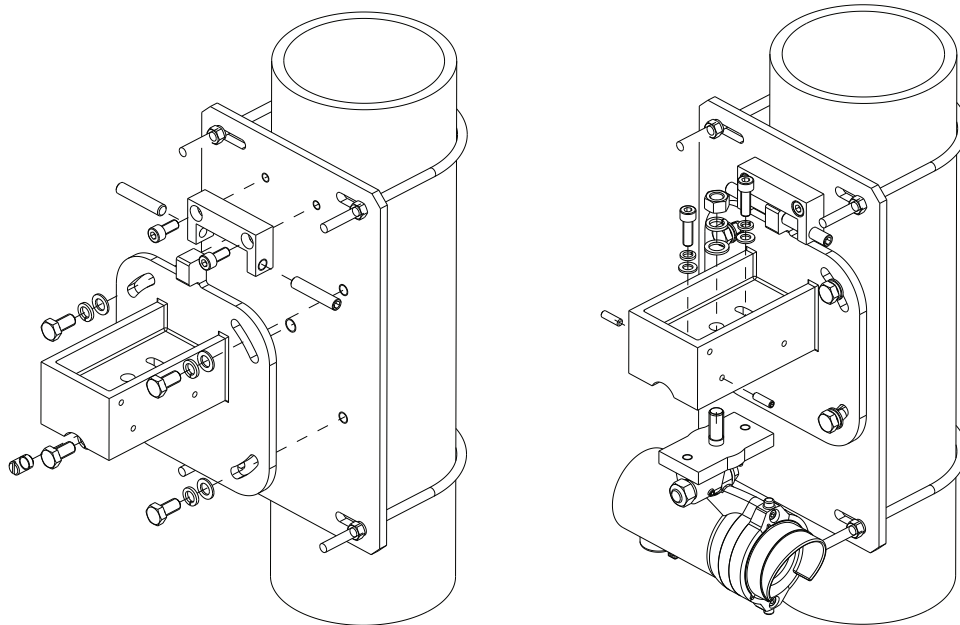

The mechanical installation procedure applies to both the Receiver and the Transmitter.

NOTE: THIS BRACKET IS DESIGNED FOR USE WITH THE SEARCHLINE EXCEL SHORT-RANGE SYSTEM ONLY. DO NOT ATTEMPT TO MOUNT MEDIUM-RANGE OR LONG-RANGE TRANSMITTER UNITS USING THE MARINE BRACKET.

(1) Fit the mounting plate to a single pipe or pole as shown: The pole should be between 100mm and 150mm in diameter (4" and 6").

APPENDIX D - MARINE BRACKET

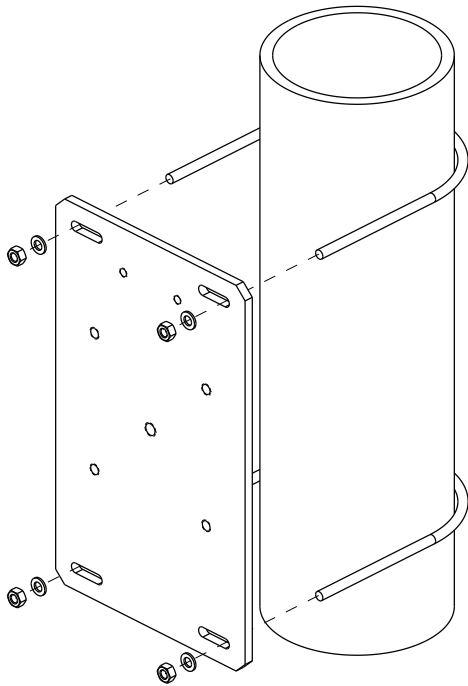

Identify the required mounting holes from the following drawing and table:

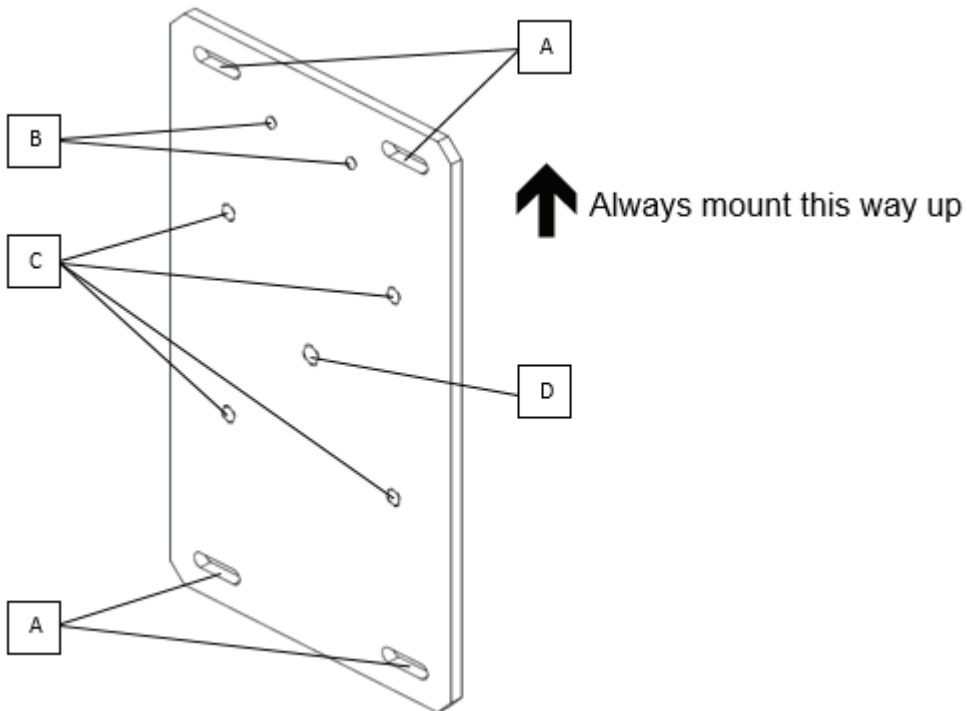

APPENDIX D - MARINE BRACKET

Notes:

1. Drawing is **NOT** to scale.
2. U-bolts are **NOT** provided.

Identify	Quantity	Size	Used For
A	4	9mm	U-bolts (2 off)
B	2	M8	Vertical Adjustment Assembly
C	4	M10	Mounting Bracket
D	1	M12	Pivot

(2) Fit the vertical adjustment assembly to the main plate with 2 screws (M8x18) using mounting holes B. Mount 2 hexagon socket screws to the vertical adjustment assembly but do not tighten fully.

(3) Fit the pivot to the mounting plate and tighten it with a screwdriver.

(4) Fit the mounting bracket to the main plate with 4 screws (M10x20) using mounting holes C, spring washers and washers but do not tighten fully.

(5) Tighten the 2 hexagon socket screws of the vertical adjustment assembly until they contact the lever of the mounting bracket.

(6) Tighten the screws of the mounting bracket.

(7) Fit the pivot block to the mounting bracket using a nut, spring washer and washer (M12). Do not tighten fully.

(8) Fit the Excel to the pivot block.

The correct orientation for the pivot and main support is as follows:

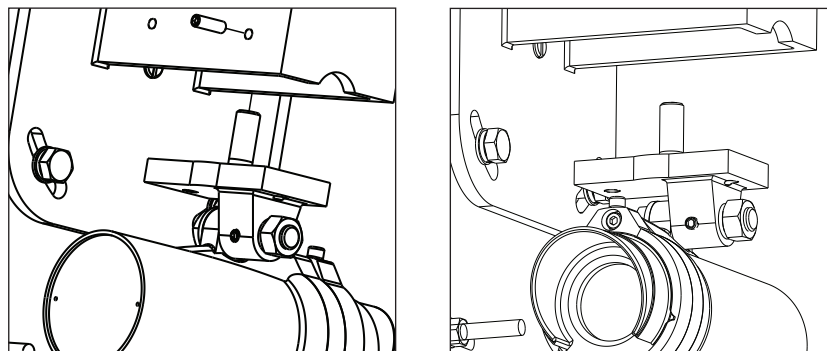

(9) Fit 2 screws (M8x25), 2 spring washers and 2 washers to the pivot block. Do not tighten fully.

(10) Fix the horizontal position of the pivot block using 2 hexagon socket screws (M6x20).

APPENDIX D - MARINE BRACKET

At this point, position the units on their mountings so that their optical windows face each other.

(11) Tighten the mounting support's nut (M12) and 2 screws (M6x20).

(12) Measure and record the distance (in metres) between the Transmitter and the Receiver units. This distance is required later in the alignment procedures.

D.2.2.3 Electrical Installation

Refer to Section 3.6.2 of this handbook.

D.2.3 Alignment and Commissioning

Refer to Section 3.7 of this handbook.

D.2.4 Sunshade Installation

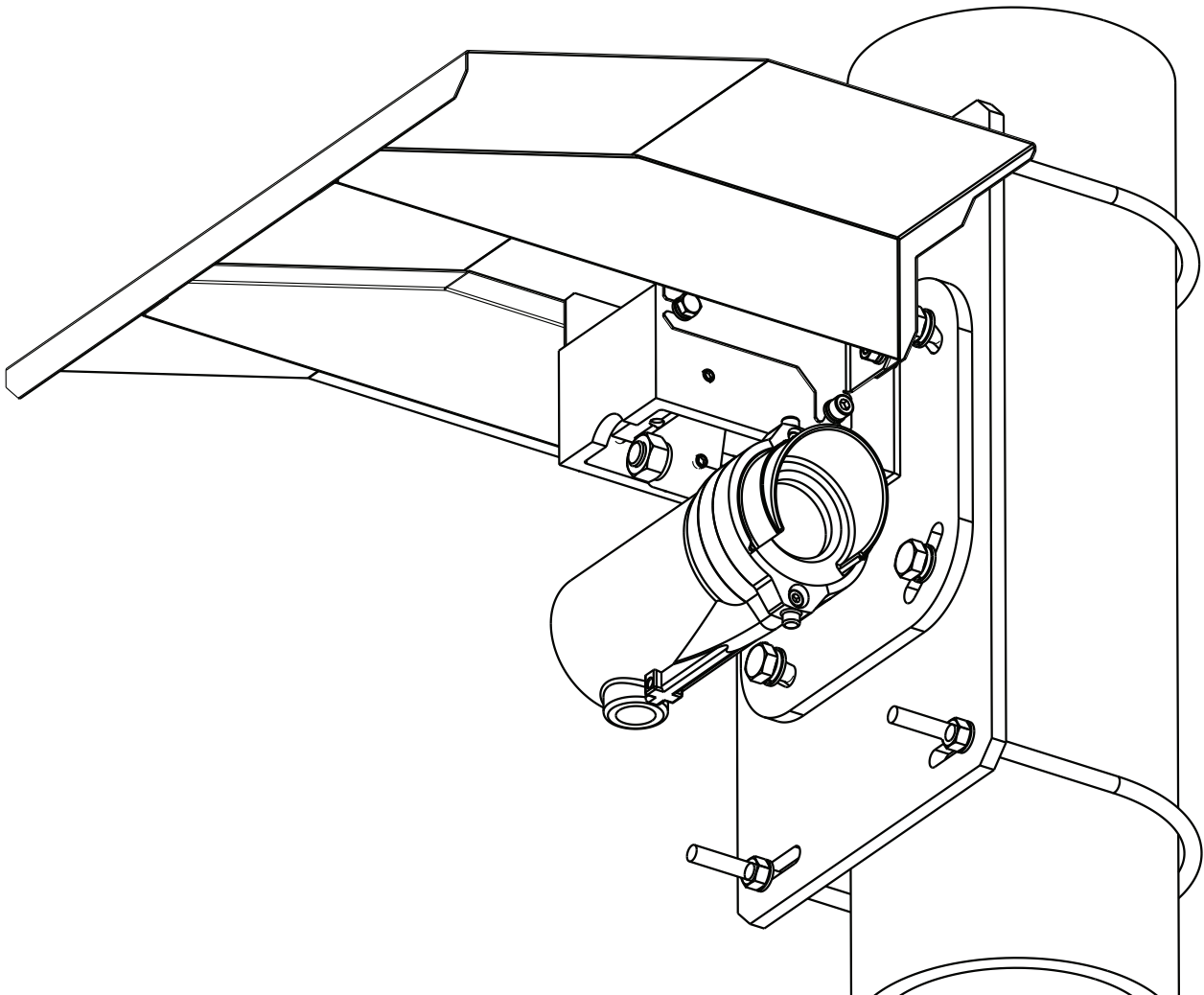

Sunshade General View

APPENDIX D - MARINE BRACKET

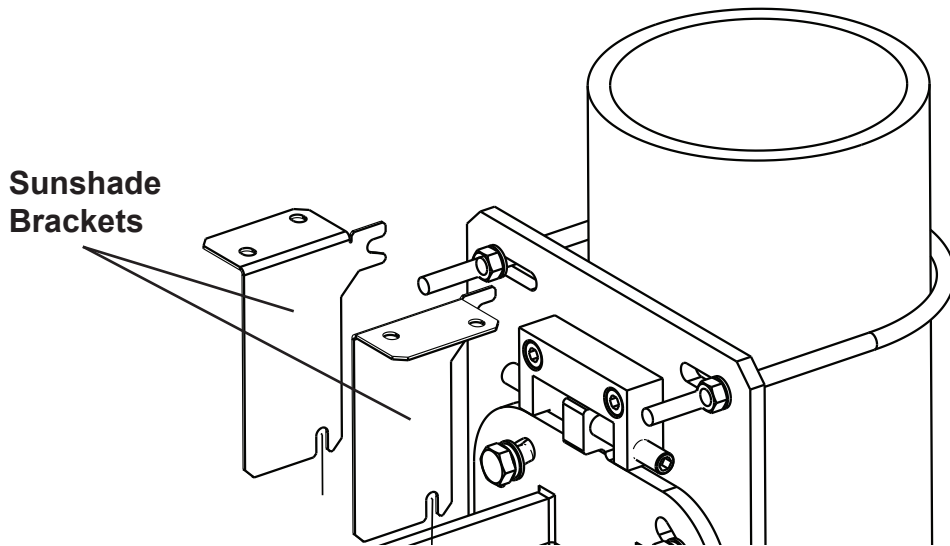

View of Sunshade Brackets

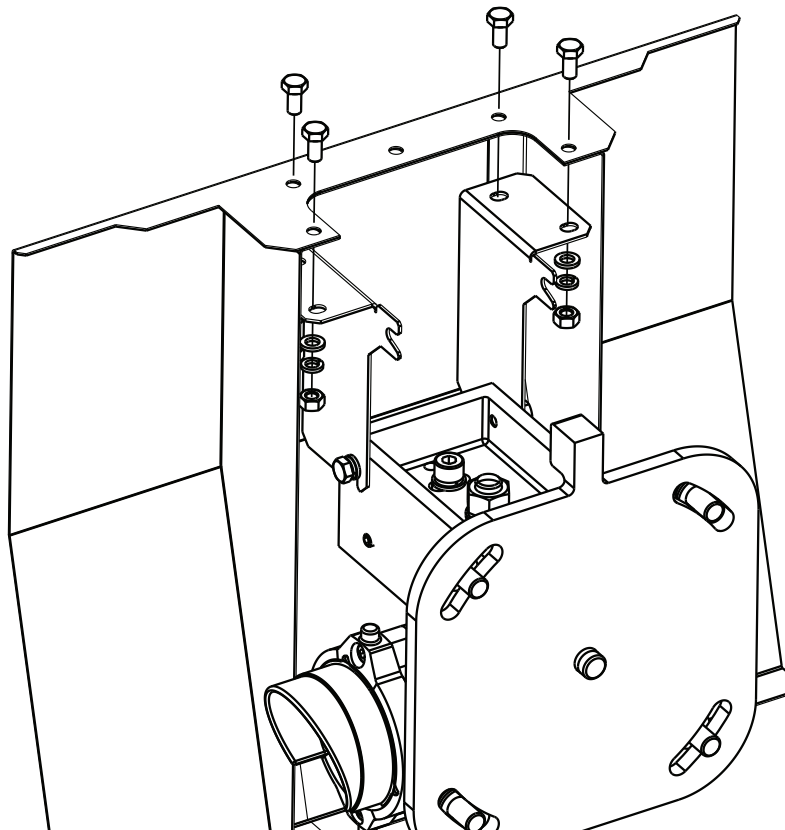

Installation View 1

APPENDIX D - MARINE BRACKET

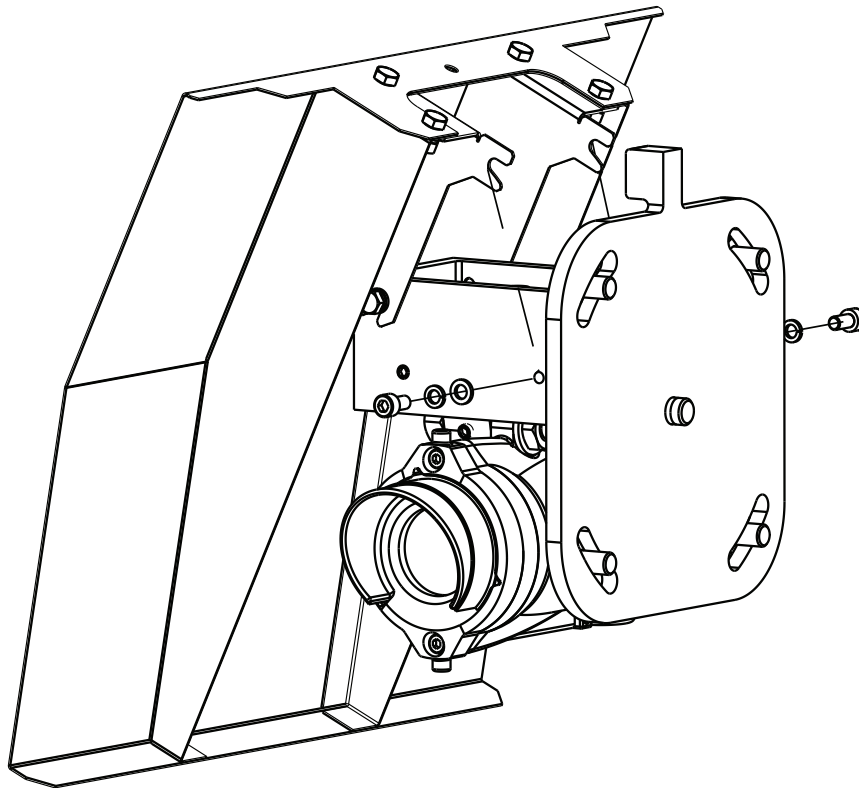

Installation View 2

D.2.4.1 Unpacking

- (1) Carefully unpack the equipment, observing any instructions that may be printed on or contained within the packaging.
- (2) Check the contents for damage and against the packing note for deficiencies.

In the event of damage or loss in transit, notify the carrier and Honeywell Analytics or your local agent immediately.

The Marine Bracket consists of the following items:

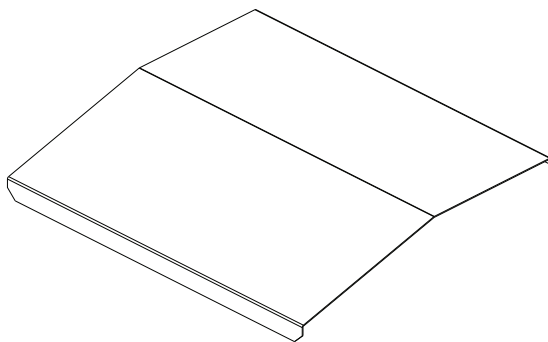

1 x Sunshade

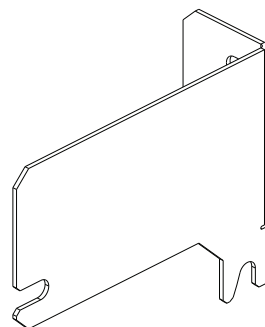

1 x Bracket L

APPENDIX D - MARINE BRACKET

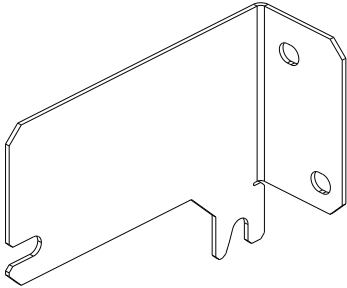

1 x Bracket R

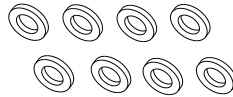

8 x Washer M6

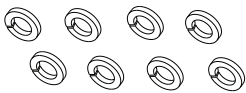

8 x Spring Washer M6

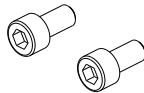

2 x Socket Cap Screw M6x12

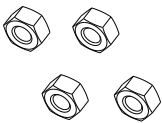

4 x Hex Nut M6

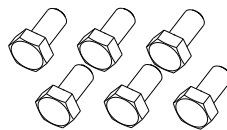

6 x Screw M6x12

D.2.4.2 Mechanical Installation

- (1) Fit the sunshade brackets to the sunshade with 4 hexagon screws (M6x12), 4 washers M6, 4 spring washers M6 and 4 hex nuts M6.
- (2) Mount 2 hexagon screws (M6x12), 2 washers M6 and 2 spring washers M6 to the mounting bracket but do not tighten fully.
- (3) Mount 2 socket cap screws (M6x12), 2 washers M6 and 2 spring washers M6 to the mounting bracket but do not tighten fully.
- (4) Slide the sunshade brackets onto 2 hexagon screws M6x12 as shown in *Installation View 2*.
- (5) Tilt the sunshade to horizontal position so that sunshade brackets slide onto 2 socket cap screws M6x12.
- (6) Tighten 2 hexagon screws M6x12 and 2 socket cap screws M6x12.

Find out more

www.honeywellanalytics.com

Contact Honeywell Analytics:

Europe, Middle East, Africa, India

Life Safety Distribution GmbH
Javastrasse 2
8604 Hegnau
Switzerland
Tel: +41 (0)44 943 4300
Fax: +41 (0)44 943 4398
India Tel: +91 124 4752700
gasdetection@honeywell.com

Americas

Honeywell Analytics Inc.
405 Barclay Blvd.
Lincolnshire, IL 60069
USA
Tel: +1 847 955 8200
Toll free: +1 800 538 0363
Fax: +1 847 955 8210
detectgas@honeywell.com

Asia Pacific

Honeywell Analytics Asia Pacific
7F SangAm IT Tower, 434 Worldcup Buk-ro,
Mapo-gu, Seoul 03922
Korea
Tel: +82-2-69090300
Fax: +82-2-69090328
analytics.ap@honeywell.com

Technical Services

EMEA: HAexpert@honeywell.com
US: HA.us.service@honeywell.com



Honeywell

AUTHORIZED DISTRIBUTOR

De Gidts & Feldman BV
The Netherlands
www.dgfg.nl



De Gidts & Feldman

INSTRUMENTATION & FILTRATION

Please Note:

While every effort has been made to ensure accuracy in this publication, no responsibility can be accepted for errors or omissions. Data may change, as well as legislation and you are strongly advised to obtain copies of the most recently issued regulations, standards and guidelines. This publication is not intended to form the basis of a contract.

Issue 15 07/2017
2104M0506
© 2017 Honeywell Analytics

Honeywell